

AC Current Transducer CVK201S

I_{PN}=50-100-200A

Transducer for the electronic measurement of AC sinusoidal waveforms, with galvanic isolation between the primary (High power) and the secondary circuit (Electronic circuit). Jumper selectable ranges and self powered transducers.



RoHS COMPLIANT

● Operating performances (AT=25 °C)

Primary current(with manual jumper)	I _{PN}	50,100,200	A
Output signal	V _{OUT}	5 @ I _{PN}	V
Supply voltage	V _{CC}	Self Powered	
Load resistance	R _L	1	MΩ
Accuracy	ε _L	±1	%
Response time	tr	< 100	ms
RMS Isolation voltage test, 50Hz,1min	X	3	KV
Rated voltage	V _b	150	V AC
Frequency bandwidth	f	50-60	Hz

● General data

Operating temperature	T _O	-25~+70°C
Storage temperature	T _S	-40~+80°C
Mass	m	140g
Note	Insulated plastic case recognized according to UL 94-V0	

● Features

◆AC sinusoidal measurement	◆Self powered transducers
◆Average responding	◆Panel mounting
◆Voltage output	◆Jumper selectable ranges

● Applications

◆ Automation systems	Analog current reading for remote monitoring(e.g.motor)
◆Data loggers	Self-powered transducer does not drain data logger batteries.
◆Panel meters	Simple connection displays power consumption.

● Advantages

◆Large aperture	◆High isolation between primary and secondary circuits
◆Easy to mount	

CVK201S

● **Internal Circuit**

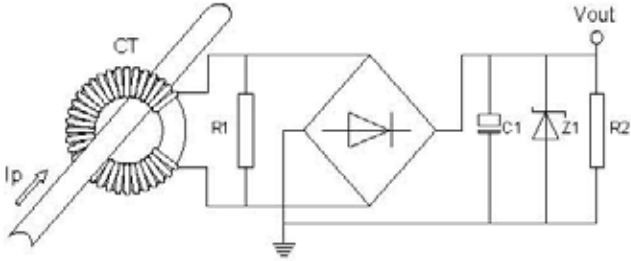

Connections

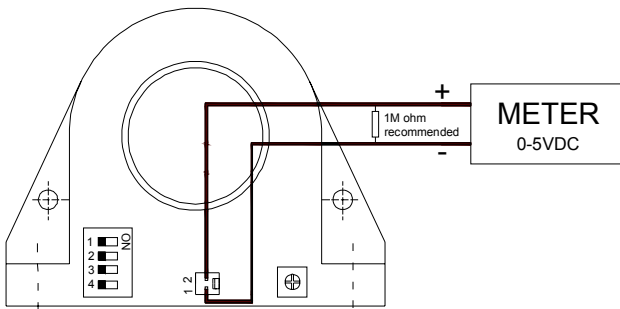

Dimensions (unit: mm/inch)

Front View

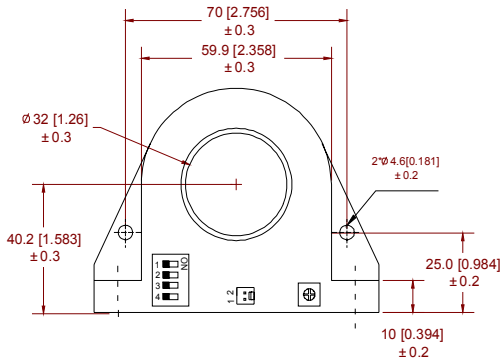

Right View

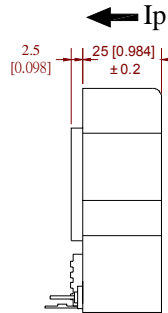

Bottom View

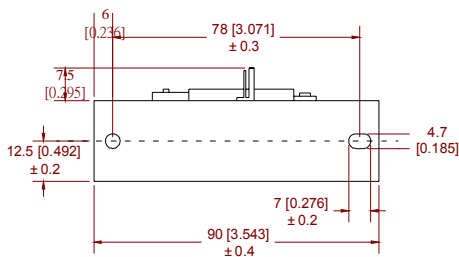

1	NO	DIP SW SETTING
2	NO	0-50A= SW1 ON
3	NO	0-100A=SW2 ON
4	NO	0-200A=SW3 ON
		N/A= SW4

Connection of secondary
 Molex 22-01-1022

● **Output Curve Figure**

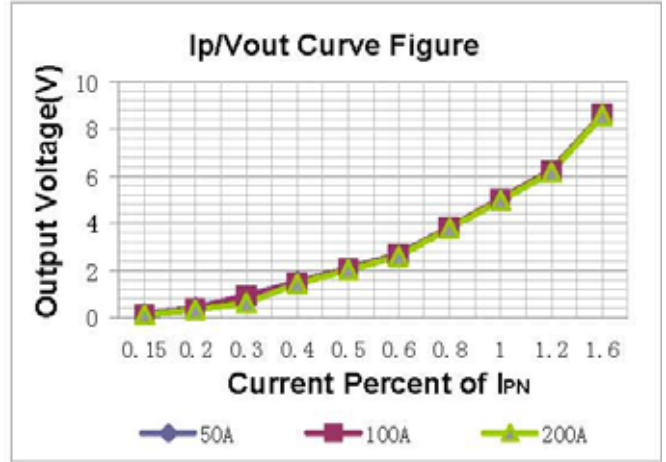

● **Remarks**

Temperature of the primary conductor should not exceed 60