

A12038

120x120x38mm
(4.7"x4.7"x1.5")



HOUSING Aluminum Die Casting, Painted Black
 IMPELLER Thermoplastic PBT, UL94V-0
 BEARING Ball or Sleeve
 MOTOR TYPE Shaded Pole Motor
 TERMINATION Terminals or Lead Wire
 OPERATING VOLTAGE RANGE 85VAC to 125VAC for 115V Type
 185VAC to 245VAC for 230V Type
 DIELECTRIC STRENGTH 1,500 VAC for 1 minute
 INSULATION Class A
 INSULATION RESISTANCE 10M Ohms min. @ 500 VDC
 OPERATING TEMPERATURE -10°C to +70°C
 SAFETY Impedance Protected
 WEIGHT 515g
 ROHS COMPLIANCE YES

120 mm

120mm

AC Fans & Blowers

DIMENSION

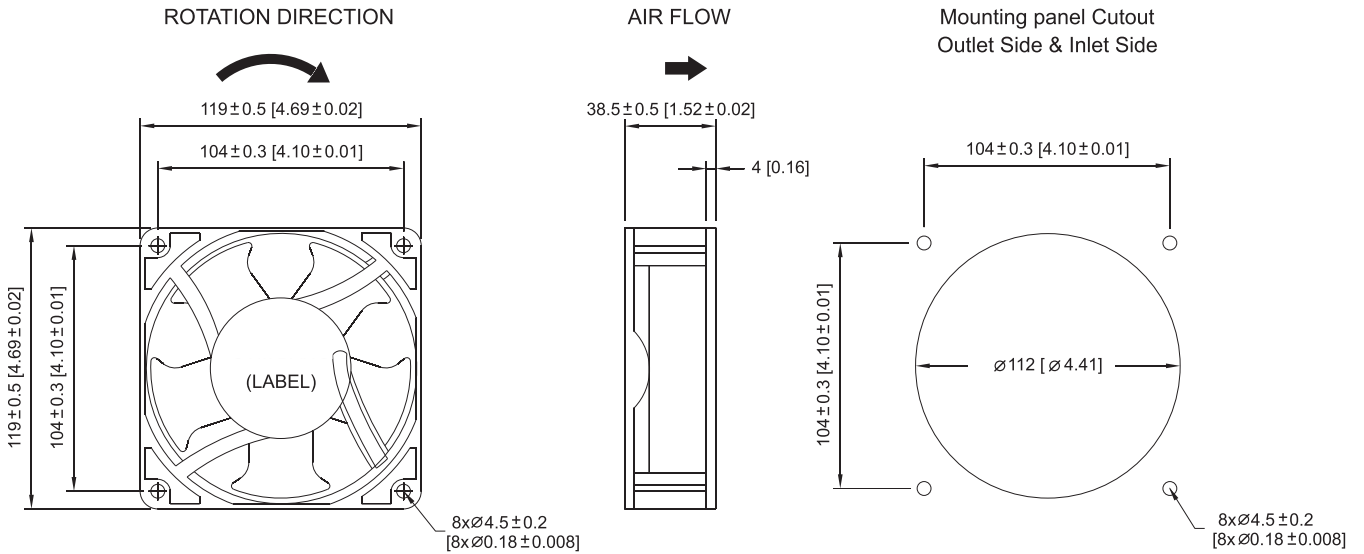

UNIT:mm[inch]

SPECIFICATION

MODEL NO.	RATED VOLTAGE (V)	FREQUENCY (Hz)	RATED CURRENT (A)	INPUT POWER (W)	SPEED (RPM)	MAX. AIR PRESSURE		MAX. AIR FLOW		NOISE dB(A) @1M
						inchH ₂ O	mmH ₂ O	CFM	m ³ /min	
A12038V1H	115	50/60	0.26/0.21	20/16	2650/3100	0.24/0.21	6.18/5.36	85/97	2.4/2.8	44/48
A12038V1M	115	50/60	0.14/0.13	11/11	2700/2450	0.21/0.08	5.33/2.14	83/81	2.3/2.2	43/42
A12038V1L	115	50/60	0.13/0.11	11/10	1900/2300	0.11/0.08	2.79/2.06	61/64	1.7/1.8	34/35
A12038V1XL	115	50/60	0.08/0.07	7/ 6	1850/1700	0.09/0.06	2.29/1.60	61/56	1.7/1.5	34/33
A12038V2H	230	50/60	0.13/0.10	20/16	2650/3100	0.24/0.21	6.18/5.36	85/97	2.4/2.8	44/48
A12038V2M	230	50/60	0.07/0.06	12/11	2700/2450	0.21/0.06	5.33/2.14	83/81	2.3/2.2	43/42
A12038V2L	230	50/60	0.07/0.06	12/10	1900/2300	0.11/0.08	2.79/2.08	61/64	1.7/1.8	34/35
A12038V2XL	230	50/60	0.05/0.04	9/ 8	1850/1700	0.09/0.06	2.29/1.60	59/59	1.6/1.6	33/33

AIR PERFORMANCE

