

# A15055M-DA



150x172x55mm  
(5.9"x6.77"x2.17")



HOUSING  
IMPELLER  
BEARING  
MOTOR TYPE  
TERMINATION  
OPERATING VOLTAGE RANGE  
  
DIELECTRIC STRENGTH  
INSULATION  
INSULATION RESISTANCE  
OPERATING TEMPERATURE  
SAFETY  
WEIGHT  
ROHS COMPLIANCE

Aluminum Die Casting, Painted Black  
Metal  
Ball  
Outer Rotor, AC Induction Capacitor Motor  
Terminals or Lead Wire  
85VAC to 125VAC for 115V Type  
185VAC to 245VAC for 230V Type  
1,500VAC for 1 second  
Class A  
10M Ohms min. @500VDC  
-10°C to + 70°C  
Thermally Protected  
840 g  
Yes

## DIMENSION

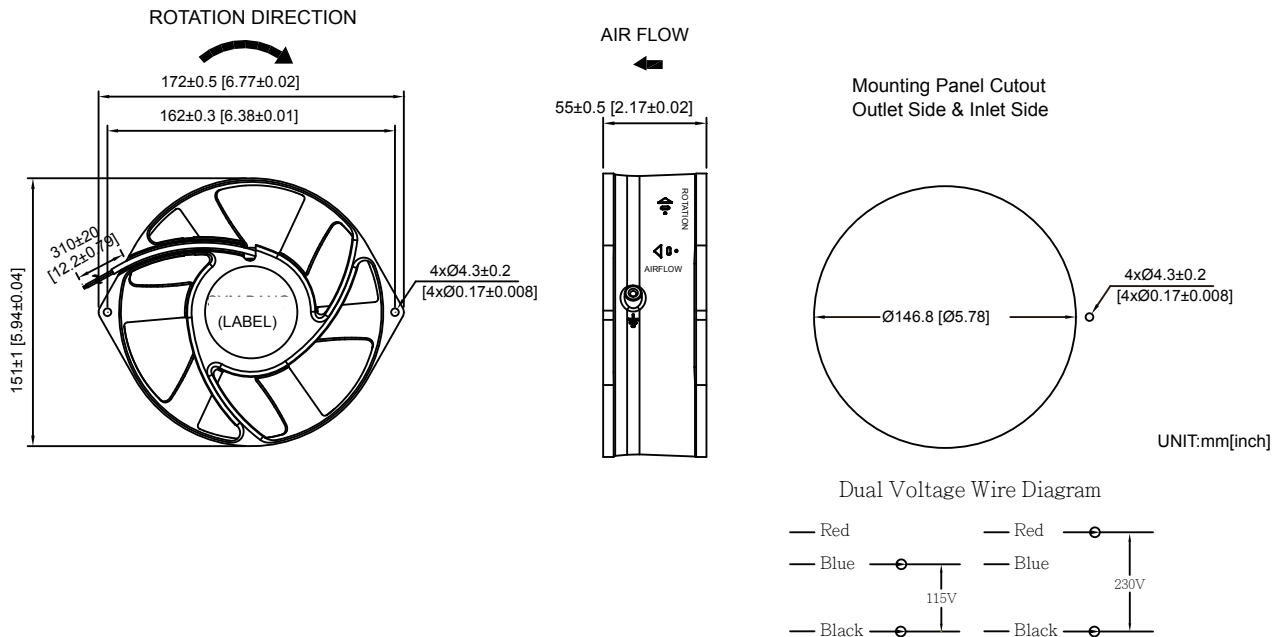

## SPECIFICATION

MODEL NO.	RATED VOLTAGE (V)	FREQUENCY (Hz)	RATED CURRENT (A)	INPUT POWER (W)	SPEED (RPM)	MAX. AIR PRESSURE		MAX. AIR FLOW		NOISE dB(A) @1M
						inchH <sub>2</sub> O	mmH <sub>2</sub> O	CFM	m <sup>3</sup> /min	
A15055V1HBM-DA	115	50/60	0.25/0.21	27/25	2700/3100	0.472/0.512	12.0/13.0	200/230	5.66/6.51	52/58
A15055V2HBM-DA	230	50/60	0.11/0.12	26/28	2700/3100	0.472/0.512	12.0/13.0	200/230	5.66/6.51	52/58
A15055DVHBLM-DA	115	50/60	0.17/0.20	20/24	2750/3100	0.43/0.28	11/7	230/240	6.51/6.80	52/28
	230	50/60	0.15/0.14	30/31	2850/3350	0.60/0.75	15/19	230/280	6.51/7.90	52/28

## AIR PERFORMANCE

