

A17051

Ø 170x51mm
(Ø 6.8"x2")



AC Fans & Blowers



HOUSING	Aluminum Die Casting, Painted Black
IMPELLER	Thermoplastic PBT, UL94V-0
BEARING	Ball
MOTOR TYPE	AC Induction Capacitor Motor
TERMINATION	Terminals or LAC Induction Capacitor Motoread wire.
OPERATING VOLTAGE RANGE	85VAC to 125VAC for 115V Type 185VAC to 245VAC for 230V Type
DIELECTRIC STRENGTH	1,500 VAC for 1 minute
INSULATION	Class A
INSULATION RESISTANCE	10M Ohms min. @ 500VDC
OPERATING TEMPERATURE	-10°C to +70°C
SAFETY	Thermally Protected
WEIGHT	875g
ROHS COMPLIANCE	Yes

170mm

170mm

DIMENSION

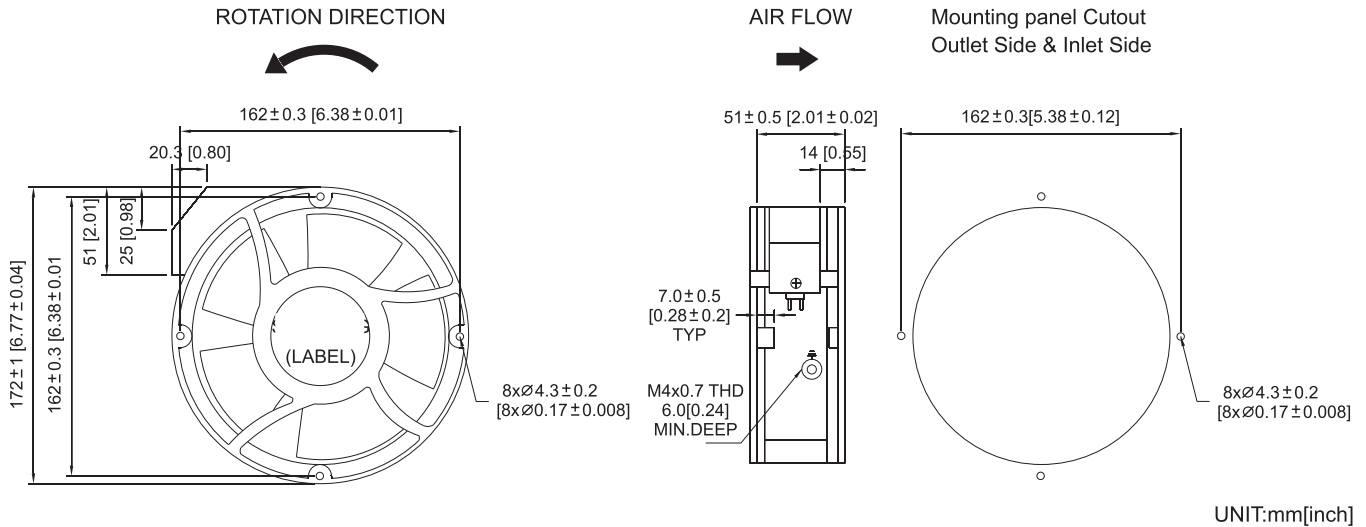

SPECIFICATION

MODEL NO.	RATED VOLTAGE (V)	FREQUENCY (Hz)	RATED CURRENT (A)	INPUT POWER (W)	SPEED (RPM)	MAX. AIR PRESSURE		MAX. AIR FLOW		NOISE dB(A) @1M
						inchH ₂ O	mmH ₂ O	CFM	m ³ /min	
A17051V1H	115	50/60	0.22/0.28	25/31	2800/3350	0.59/0.61	15.1/15.6	195/225	5.57/6.42	57/61
A17051V1L	115	50/60	0.15/0.15	17/16	1400/1800	0.18/0.25	4.57/6.35	100/121	2.83/3.41	39/44
A17051V2H	230	50/60	0.11/0.14	24/30	2800/3350	0.59/0.61	15.1/15.6	195/225	5.57/6.42	57/61
A17051V2L	230	50/60	0.06/0.06	14/13	1400/1800	0.18/0.25	4.57/6.35	101/120	2.85/3.41	39/44

AIR PERFORMANCE

