

A18065-S



180x180x65mm
(7.09"x7.09"x2.56")



HOUSING Aluminum Die Casting, Painted Black
 IMPELLER Thermoplastic PBT, UL94V-0
 BEARING Ball
 MOTOR TYPE AC Induction Capacitor Motor
 TERMINATION Terminals or Lead Wire
 OPERATING VOLTAGE RANGE 85VAC to 125VAC for 115VAC Type
 185VAC to 245VAC for 230VAC Type
 DIELECTRIC STRENGTH 1,500 VAC for 1 minute
 INSULATION Class A
 INSULATION RESISTANCE 10M Ohms min. @ 500VDC
 OPERATING TEMPERATURE -10°C to +70°C
 SAFETY Thermally Protected
 WEIGHT 1800g
 ROHS COMPLIANCE Yes
 ADDITIONAL FUNCTION FG, RD

180mm

AC Fans & Blowers

180mm

DIMENSION

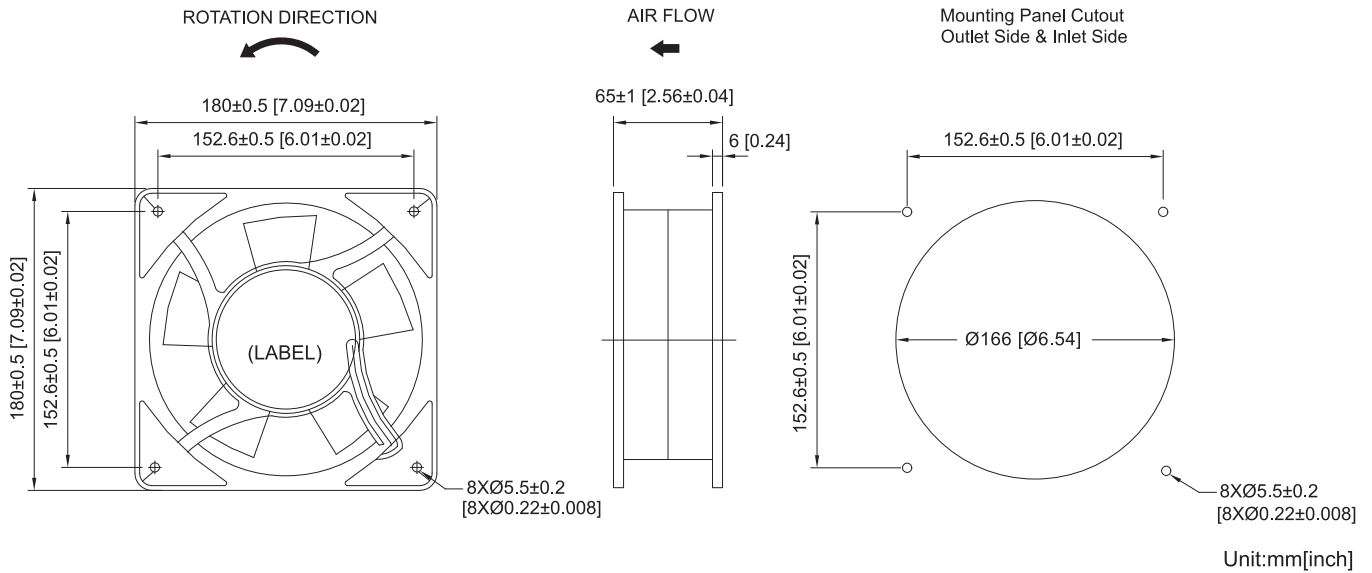

SPECIFICATION

MODEL NO.	RATED VOLTAGE (V)	FREQUENCY (Hz)	RATED CURRENT (A)	INPUT POWER (W)	SPEED (RPM)	MAX. AIR PRESSURE		MAX. AIR FLOW		NOISE dB(A) @1M
						inchH ₂ O	mmH ₂ O	CFM	m ³ /min	
A18065V1H-S	115	50/60	0.56/0.48	52/56	2800/3250	0.59/0.76	15.1/19.4	355/395	10.0/11.1	62
A18065V2H-S	230	50/60	0.20/0.23	44/53	2800/3250	0.59/0.76	15.1/19.4	355/395	10.0/11.1	62

AIR PERFORMANCE

