

# A 28089



280x280x89mm  
(11.02"x11.02"x3.5")



HOUSING	Aluminum Die Casting, Painted Black
IMPELLER	Thermoplastic PBT, UL94V-0
BEARING	Ball
MOTOR TYPE	AC Induction Capacitor Motor
TERMINATION	Terminals or Lead Wire
OPERATING VOLTAGE RANGE	85VAC to 125VAC for 115V Type 185VAC to 245VAC for 230V Type
DIELECTRIC STRENGTH	1,500 VAC for 1 minute
INSULATION	Class A
INSULATION RESISTANCE	10M Ohms min. @ 500VDC
OPERATING TEMPERATURE	-10°C to + 70°C
SAFETY	Thermally Protected
WEIGHT	3850g
ROHS COMPLIANCE	Yes

# 280mm

AC Fans & Blowers

## DIMENSION

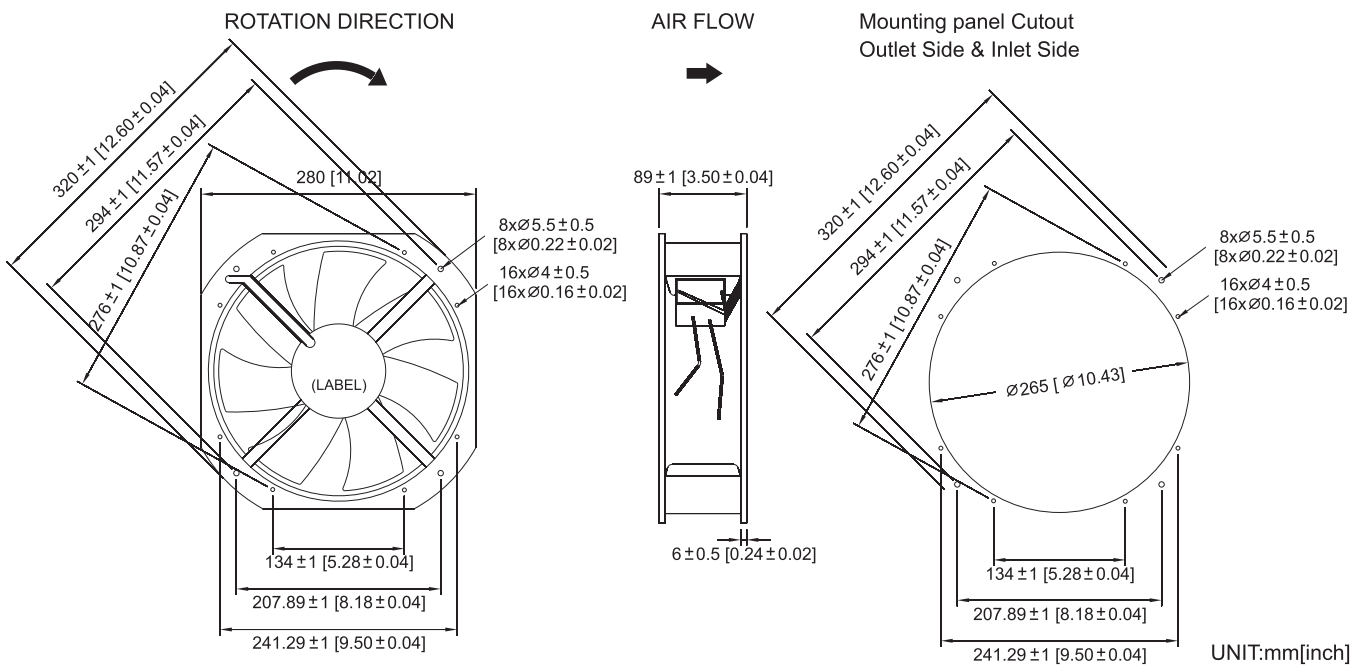

## SPECIFICATION

MODEL NO.	RATED VOLTAGE (V)	FREQUENCY (Hz)	RATED CURRENT (A)	INPUT POWER (W)	SPEED (RPM)	MAX. AIR PRESSURE		MAX. AIR FLOW		NOISE dB(A) @1M
						inchH <sub>2</sub> O	mmH <sub>2</sub> O	CFM	m <sup>3</sup> /min	
A28089V1H	115	50/60	1.8 / 2.5	196/273	2800/3250	1.24/1.06	31.59/26.84	1320/1450	37.35/41.03	70/74
A28089V2H	230	50/60	0.7 / 1.1	175/258	2800/3200	1.24/1.06	31.59/26.84	1320/1450	37.35/41.03	70/74
A28089V4H	480	60	0.58	275	3250	1.06	26.84	1450	41.03	74

## AIR PERFORMANCE

