

ACB350180 Single Inlet Blower



350x180mm, 4 Poles
(13.78"x7.09")



MOTOR
HOUSING
IMPELLER
BEARING
INSULATION
OPERATING TEMPERATURE
INSULATION RESISTANCE
DIELECTRIC STRENGTH
SAFETY
WEIGHT
ROHS COMPLIANCE

Outer rotor motor $\varnothing 92\text{mm}$
Steel Painted Black Scroll
Steel
Ball
Class F
 $0^{\circ}\text{C} \sim +65^{\circ}\text{C}$
10M Ohms Min. @500VDC
5mA Max. at 1500 VAC for 1 minute
Thermally Protected
7.0kg
YES

350 mm

DIMENSION

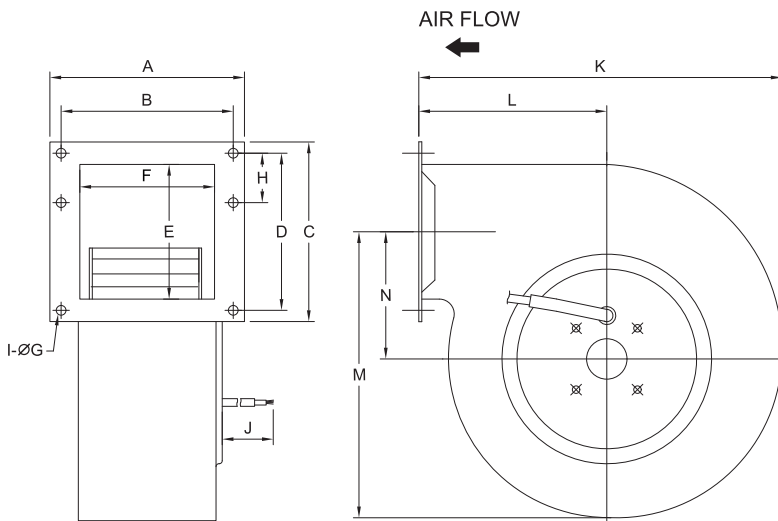

WIRE DIAGRAM

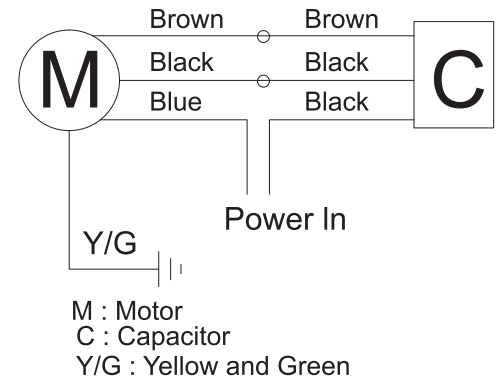

MODEL NO.	DIMENSION(mm)													WEIGHT (Kg)
	A	B	C	D	E	F	G	I	J	K	L	M	N	
ACB350180-4P	180	160	180	160	124	124	6.5	4	560	350	170	286	140	7.0

UNIT:mm

SPECIFICATION

MODEL NO.	RATED VOLTAGE(V)	FREQUENCY (Hz)	RATED CURRENT(A)	INPUT POWER(W)	SPEED (RPM)	MAX. AIR PRESSURE		MAX. AIR FLOW		NOISE dB(A)@1M	CAPACITOR $\mu\text{F}/\text{Vac}$
						inchH ₂ O	mmH ₂ O	CFM	m ³ /min		
ACB350180V1H4P	110	60	2.30	240	1050	1.50	38.25	524	14.83	67	20/250
ACB350180V2H4P	220	50/60	1.00/1.15	205/240	1140/1050	1.06/1.50	27.13/38.25	565/524	16/14.83	68/67	4/450

AIR PERFORMANCE

