

ACF 28092~114



Ø280x92~114mm, 2 Poles & 4 Poles
(Ø11"x3.62"~4.48")



- MOTOR: Outer rotor motor Ø92mm
- IMPELLER: Metal
- BEARING: Ball
- TERMINATION: Lead Wire
- DIELECTRIC STRENGTH: 5mA Max.at 1500 VAC for 1 minute
- INSULATION: Class F
- INSULATION RESISTANCE: 10M Ohms Min. @500VDC
- OPERATING TEMPERATURE: 0°C ~ +65 °C
- SAFETY: Thermally Protected
- ROHS COMPLIANCE: YES

280 mm

DIMENSION

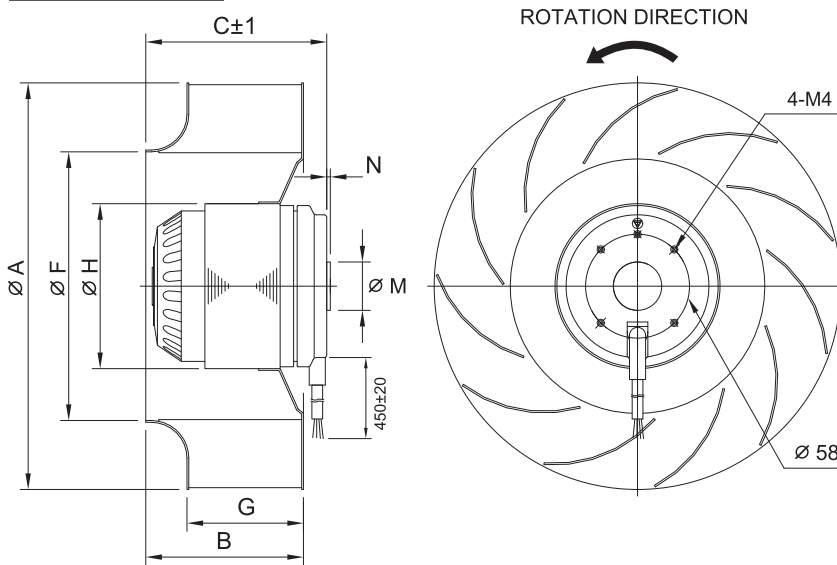

WIRE DIAGRAM

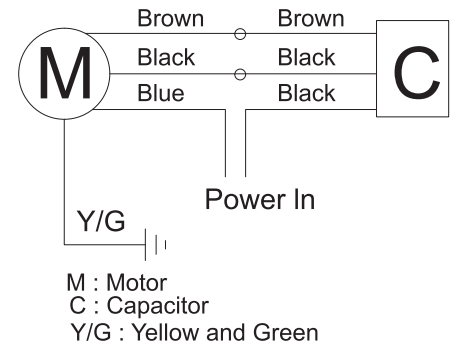

UNIT:mm

MODEL NO.	DIMENSION(mm)								WEIGHT (Kg)
	A	B	C	F	G	H	M	N	
ACF28092-2P	280	72	92	210	44	92	27	2	3.3
ACF280114-4P	280	106	114	210	78	92	27	2	3.6

SPECIFICATION

MODEL NO.	RATED VOLTAGE(V)	FREQUENCY (Hz)	RATED CURRENT (A)	INPUT POWER(W)	SPEED (RPM)	MAX. AIR PRESSURE		MAX. AIR FLOW		NOISE dB(A)@1M	CAPACITOR uF/Vac
						inchH ₂ O	mmH ₂ O	CFM	m ³ /min		
ACF28092V1H2P	110	60	2.8	300	2370	3.45	87.7	724	20.5	75	30/250
ACF28092V2H2P	220	50/60	1.08/1.40	234/307	2310/2370	2.87/3.45	72.9/87.7	706/724	20.0/20.5	73/75	8/450
ACF28092V1H4P	110	60	1.34	145	1645	1.43	36.2	689	19.50	67	16/250
ACF28092V2H4P	220	50/60	0.67/0.70	130/145	1390/1645	1.02/1.43	26.0/36.2	611/689	17.3/19.5	62/67	4/450

AIR PERFORMANCE

