

ACF355128-HL



Ø355x128mm
(13.98"x5.04")



MOTOR	Outer rotor motor Ø102mm
IMPELLER	Aluminum
BEARING	Ball
TERMINATION	Lead Wire
DIELECTRIC STRENGTH	5mA Max. at 1500 VAC for 1 minute
INSULATION	Class A
INSULATION RESISTANCE	10M Ohms Min. @500 VDC
OPERATING TEMPERATURE	0°C to + 65°C
SAFETY	Thermally Protected
WEIGHT	4.2 kg
ROHS COMPLIANCE	Yes
CAPACITOR	8uF/450VAC

DIMENSION

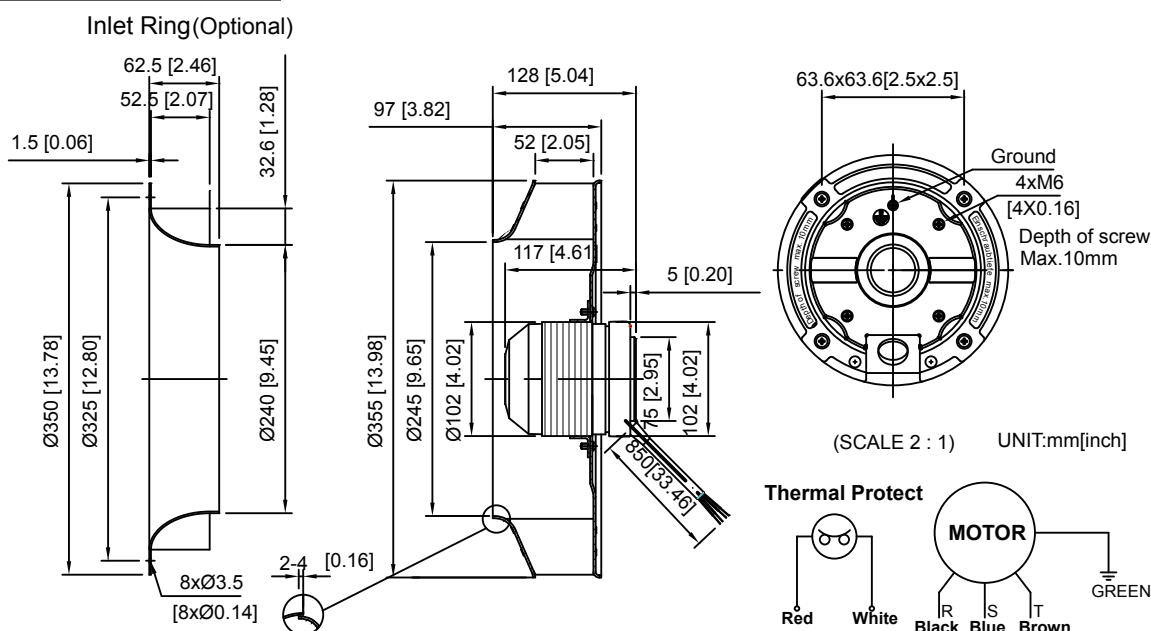

SPECIFICATION

MODEL NO.	RATED VOLTAGE (V)	FREQUENCY (Hz)	RATED CURRENT (A)	INPUT POWER (W)	SPEED (RPM)	MAX. AIR PRESSURE inchH ₂ O mmH ₂ O	MAX. AIR FLOW CFM m ³ /min	NOISE dB(A) @1M
ACF355128V2H4PS-HL	220	50	0.737	160	1390	1.24 31.62	1130 32	54

AIR PERFORMANCE

