

# ECF 316160



Ø 316x160mm  
(Ø 12.44"x6.3")



MOTOR  
IMPELLER  
BEARING  
INSULATION  
OPERATING TEMPERATURE  
INSULATION RESISTANCE  
DIELECTRIC STRENGTH  
WEIGHT  
ROHS COMPLIANCE

Outer roter moter Ø92mm  
Alumiunm,painted Black  
Ball  
ClassA  
-20 °C to +60 °C  
10M Ohms Min. @500VDC  
5mA Max.at 1500 VAC for 1 minute  
3.13 kg  
YES

# 316 mm

## DIMENSION

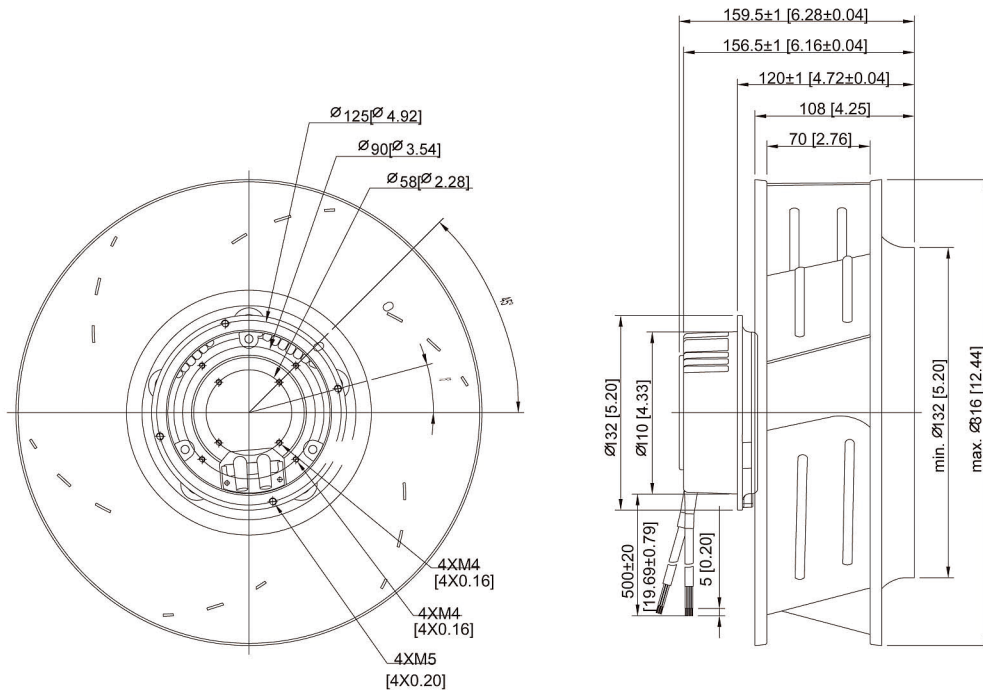

## SPECIFICATION

| MODEL NO.     | RATED VOLTAGE(V) | FREQUENCY (Hz) | RATED CURRENT(A) | INPUT POWER(W) | SPEED (RPM) | MAX. AIR PRESSURE<br>inchH <sub>2</sub> O    mmH <sub>2</sub> O | MAX. AIR FLOW<br>CFM    m <sup>3</sup> /min | NOISE<br>dB(A)@1M |
|---------------|------------------|----------------|------------------|----------------|-------------|---|---|-------------------|
| ECF316160V2HB | 230              | 50             | 1.0              | 140            | 1700        | 2.07    52.7  | 1118    31.66                               | 64                |

## AIR PERFORMANCE

