

D15038-C



162x150x38mm
(6.38"x5.91"x1.50")



HOUSING
IMPELLER
BEARING
MOTOR TYPE
INSULATION RESISTANCE
DIELECTRIC STRENGTH
WEIGHT
ROHS COMPLIANCE

Aluminum Die Casting, Painted Black
Thermoplastic PBT, UL94V-0
Ball or Sleeve
-10°C to + 60°C
10M Ohms Min. @500 VDC
5 mA Max. at 500 VAC 60Hz for 1 second
625g
Yes

DIMENSION

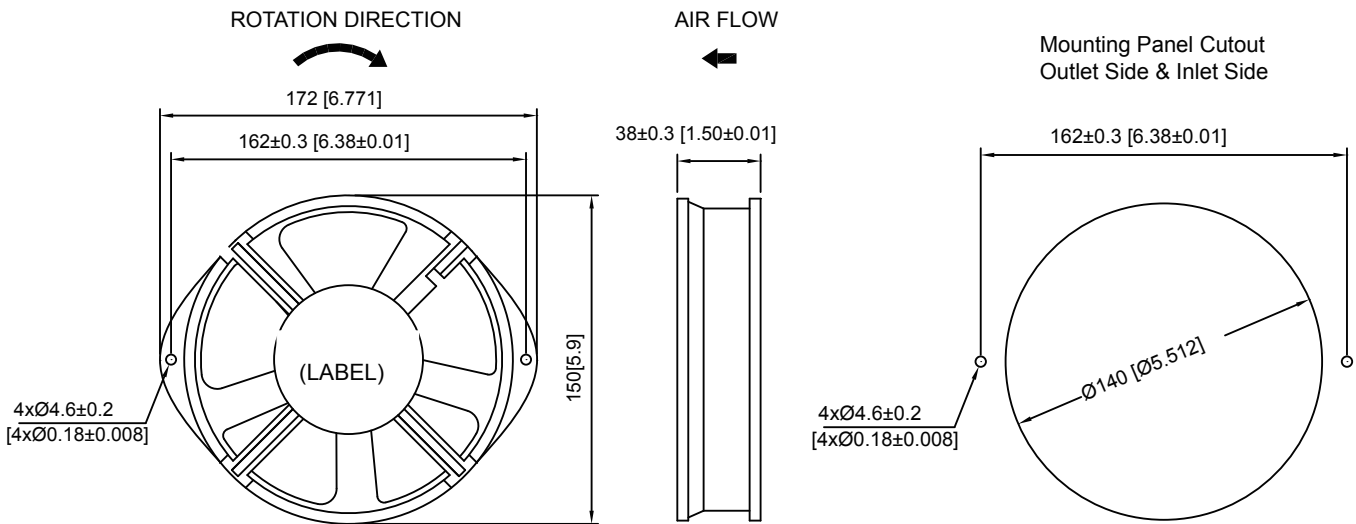

UNIT:mm[inch]

SPECIFICATION

MODEL NO.	RATED VOLTAGE (V)	RATED CURRENT (A)	INPUT POWER (W)	SPEED (RPM)	MAX. AIR PRESSURE		MAX. AIR FLOW		NOISE dB(A) @1M
					inchH ₂ O	mmH ₂ O	CFM	m ³ /min	
D15038V12HB-C	12	0.75	9.00	2200	0.22	5.61	140	3.97	42
D15038V12MB-C	12	0.55	6.60	1800	0.18	4.48	110	3.12	38
D15038V24HB-C	24	0.40	9.60	2200	0.22	5.61	140	3.97	42
D15038V24MB-C	24	0.35	8.40	1800	0.18	4.48	110	3.12	38
D15038V48HB-C	48	0.23	11.00	2200	0.22	5.61	140	3.97	42
D15038V48MB-C	48	0.19	9.12	1800	0.18	4.48	110	3.12	38

AIR PERFORMANCE

