

D15055



150x150x55mm
(5.9"x6.77"x2.17")



HOUSING
IMPELLER
BEARING
OPERATING TEMPERATURE
INSULATION RESISTANCE
DIELECTRIC STRENGTH
WEIGHT
ROHS COMPLIANCE

Aluminum Die Casting, Painted Black
Thermoplastic PBT, UL94V-0
Ball
-20°C to + 70°C
10M Ohms mins@500 VDC
5mA Max. at 500VAC 60Hz for 1 minute
1030g
Yes

DIMENSION

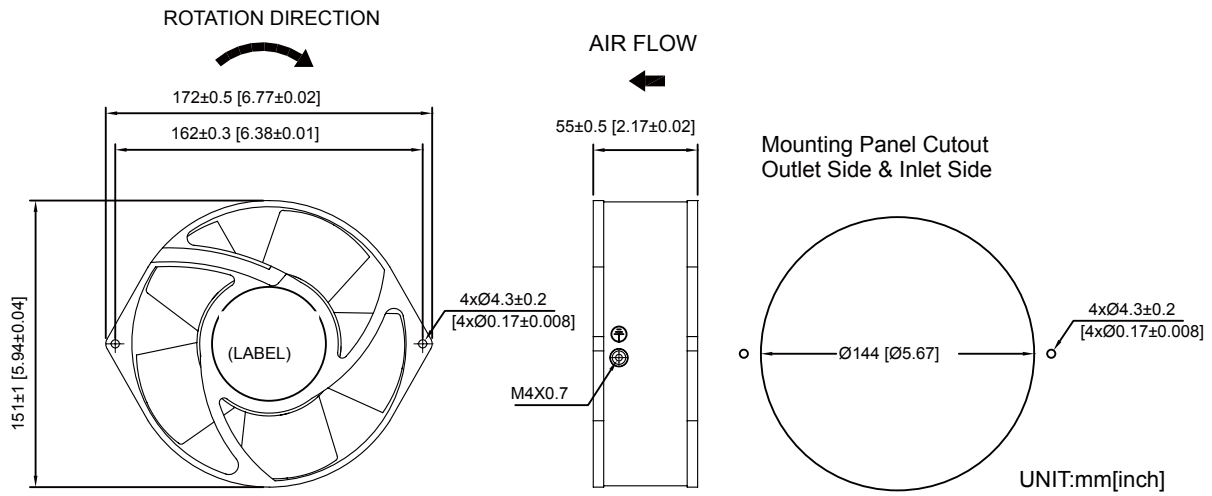

SPECIFICATION

MODEL NO.	RATED VOLTAGE (V)	RATED CURRENT (A)	INPUT POWER (W)	SPEED (RPM)	MAX. AIR PRESSURE		MAX. AIR FLOW		NOISE dB(A) @1M
					inchH ₂ O	mmH ₂ O	CFM	m ³ /min	
D15055V12LB-DA	12	1.21	14.52	2800	0.55	13.9	205	5.80	53
D15055V12MB-DA	12	1.82	21.84	3200	0.72	18.2	240	6.79	57
D15055V12HB-DA	12	2.61	31.32	3600	0.90	22.9	275	7.78	61
D15055V12SLB-DA	12	3.74	44.88	4000	1.11	28.3	310	8.77	65
D15055V24LB-DA	24	0.59	14.16	2800	0.55	13.9	205	5.80	53
D15055V24MB-DA	24	0.84	20.16	3200	0.72	18.2	240	6.79	57
D15055V24HB-DA	24	1.21	29.04	3600	0.90	22.9	275	7.78	61
D15055V24SLB-DA	24	1.50	36.00	4000	1.11	28.3	310	8.77	65
D15055V24SMB-DA	24	2.08	49.92	4400	1.32	33.6	340	9.62	69
D15055V24SHB-DA	24	2.46	59.04	4800	1.56	39.7	375	10.61	73
D15055V48LB-DA	48	0.30	14.40	2800	0.55	13.9	205	5.80	53
D15055V48MB-DA	48	0.42	20.16	3200	0.72	18.2	240	6.79	57
D15055V48HB-DA	48	0.58	27.84	3600	0.90	22.9	275	7.78	61
D15055V48SLB-DA	48	0.75	36.00	4000	1.11	28.3	310	8.77	65
D15055V48SMB-DA	48	1.04	49.92	4400	1.32	33.6	340	9.62	69
D15055V48SHB-DA	48	1.23	59.04	4800	1.56	39.7	375	10.61	73

AIR PERFORMANCE

