

D18065



180x180x65mm
(7.09"x7.09"x2.56")



HOUSING
IMPELLER
BEARING
OPERATING TEMPERATURE
INSULATION RESISTANCE
DIELECTRIC STRENGTH
WEIGHT
ROHS COMPLIANCE

Aluminum Die Casting, Painted Black
Thermoplastic PBT, UL94V-0
Ball
-10°C to + 60°C
10M Ohms Min. @500 VDC
5mA Max. at 500 VAC 60Hz for 1 minute
1500g
Yes

DIMENSION

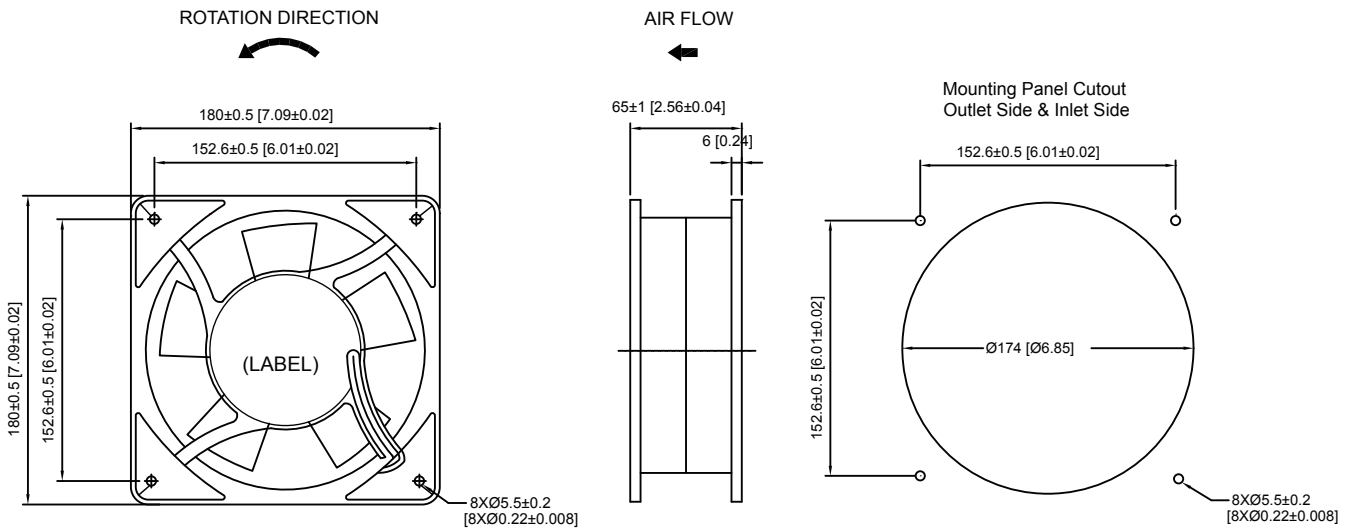

UNIT:mm[inch]

SPECIFICATION

MODEL NO.	RATED VOLTAGE (V)	RATED CURRENT (A)	INPUT POWER (W)	SPEED (RPM)	MAX. AIR PRESSURE		MAX. AIR FLOW		NOISE dB(A) @1M
					inchH ₂ O	mmH ₂ O	CFM	m ³ /min	
D18065V24SL	24	2.20	52.8	3500	0.91	23.0	450	12.7	65
D18065V24H	24	1.60	38.4	3100	0.79	20.0	400	11.3	56
D18065V24M	24	0.88	21.1	2600	0.57	14.5	330	9.3	47
D18065V24L	24	0.66	15.8	2300	0.45	11.5	300	8.5	42
D18065V48SL	48	1.10	52.8	3500	0.91	23.0	450	12.7	65
D18065V48H	48	0.80	38.4	3100	0.79	20.0	400	11.3	56
D18065V48M	48	0.44	21.1	2600	0.57	14.5	330	9.3	47
D18065V48L	48	0.33	15.8	2300	0.45	11.5	300	8.5	42

AIR PERFORMANCE

