

D 25089-K



Ø 254x89mm
(Ø 10"x3.5")



HOUSING Aluminum Die Casting, Painted Black
 IMPELLER Thermoplastic PBT, UL94V - 0
 BEARING Ball
 OPERATING TEMPERATURE -10°C to + 60°C
 INSULATION RESISTANCE 10M Ohms Min.@500 VDC
 DIELECTRIC STRENGTH 5 mA Max. at 500 VAC 60Hz for 1 minute
 WEIGHT 2200g
 ROHS COMPLIANCE Yes

250_{mm}

250mm

DC Fans & Blowers

DIMENSION

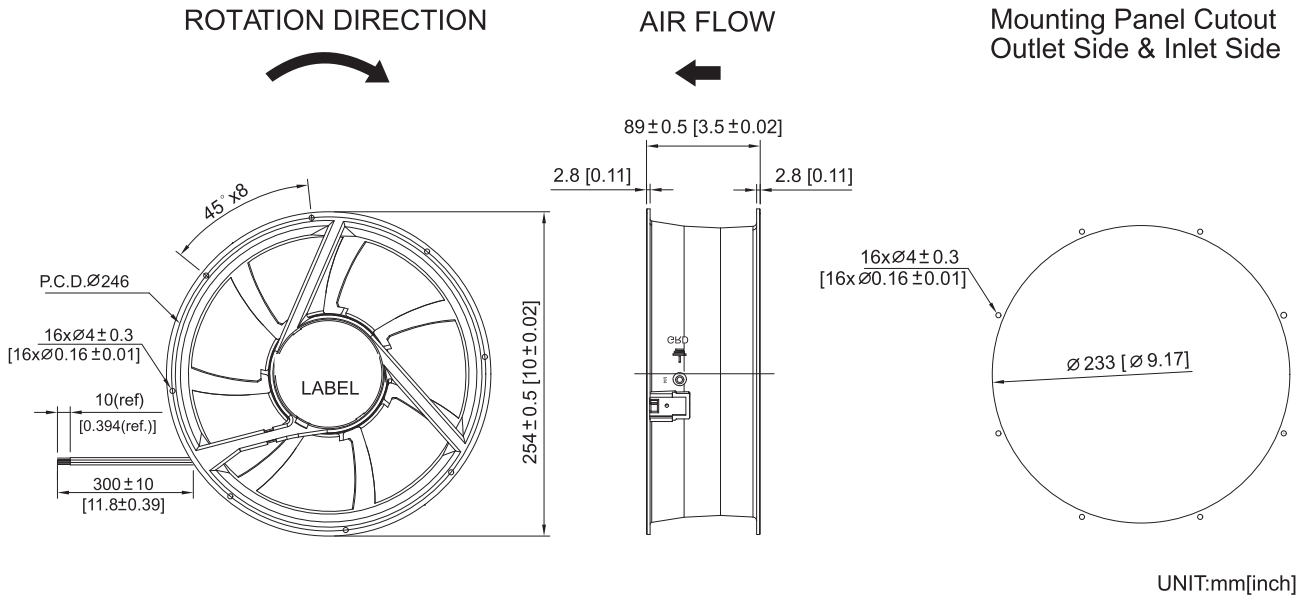

SPECIFICATION

MODEL NO.	RATED VOLTAGE (V)	RATED CURRENT (A)	INPUT POWER (W)	SPEED (RPM)	MAX. AIR PRESSURE		MAX. AIR FLOW		NOISE dB(A) @1M
					inchH ₂ O	mmH ₂ O	CFM	m ³ /min	
D25089V24SLB-K	24	1.30	31.20	2000	0.52	13.2	760	21.5	63.3
D25089V24HB-K	24	1.00	24.00	1700	0.42	10.4	640	18.1	59.1
D25089V24MB-K	24	0.80	19.20	1200	0.20	5.0	455	12.8	52.2
D25089V48SLB-K	48	1.10	52.80	2000	0.52	13.2	760	21.5	63.3
D25089V48HB-K	48	0.85	40.80	1700	0.42	10.7	640	18.1	59.1
D25089V48MB-K	48	0.63	30.24	1200	0.20	5.0	455	12.8	52.2

AIR PERFORMANCE

