

D 6015-K



60x60x15mm
(2.36"x2.36"x0.59")



HOUSING Thermoplastic PBT, UL94V-0
 IMPELLER Thermoplastic PBT, UL94V-0
 BEARING Ball or Sleeve
 OPERATING TEMPERATURE -10°C to +60°C
 INSULATION RESISTANCE 10M Ohms Min.@500 VDC
 DIELECTRIC STRENGTH 5 mA Max. at 500 VAC 60Hz for 1 minute
 WEIGHT 35g
 ROHS COMPLIANCE Yes

60 mm

60mm

DC Fans & Blowers

DIMENSION

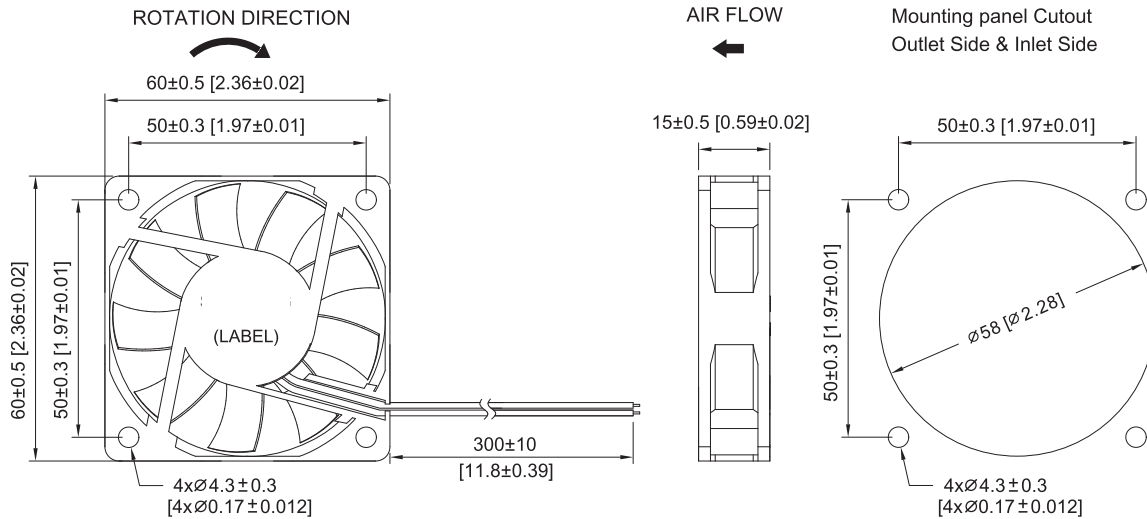

UNIT:mm[inch]

SPECIFICATION

MODEL NO.	RATED VOLTAGE (V)	RATED CURRENT (A)	INPUT POWER (W)	SPEED (RPM)	MAX. AIR PRESSURE		MAX. AIR FLOW		NOISE dB(A) @1M
					inchH ₂ O	mmH ₂ O	CFM	m ³ /min	
D6015V12SL-K	12	0.26	3.12	5000	0.23	5.7	26.5	0.75	37
D6015V12H-K	12	0.18	2.16	4500	0.18	4.6	23.1	0.65	35
D6015V12M-K	12	0.14	1.68	4000	0.16	4.1	21.7	0.62	32
D6015V12L-K	12	0.12	1.44	3500	0.14	3.5	19.0	0.54	29
D6015V12XL-K	12	0.10	1.20	3000	0.09	2.3	15.0	0.46	24
D6015V24SL-K	24	0.11	2.64	5000	0.23	5.7	26.5	0.75	37
D6015V24H-K	24	0.10	2.40	4500	0.18	4.6	23.1	0.65	35
D6015V24M-K	24	0.08	1.92	4000	0.16	4.1	21.7	0.62	32
D6015V24L-K	24	0.06	1.44	3500	0.14	3.5	19.0	0.54	29
D6015V24XL-K	24	0.04	0.96	3000	0.09	2.3	15.0	0.43	24

AIR PERFORMANCE

