

# DB 18970



189x183x70mm  
(7.44"x7.20"x2.75")



HOUSING  
IMPELLER  
BEARING  
OPERATING TEMPERATURE  
INSULATION RESISTANCE  
DIELECTRIC STRENGTH  
WEIGHT  
ROHS COMPLIANCE

Aluminum Die Casting, Natural, Milled or Black Painted  
Thermoplastic PBT, Glass Fiber30%  
Ball  
-10°C to + 60°C  
10M Ohms Min. @500 VDC  
5mA Max. at 500VAC 60Hz for 1 minute  
1450g  
Yes

## DIMENSION

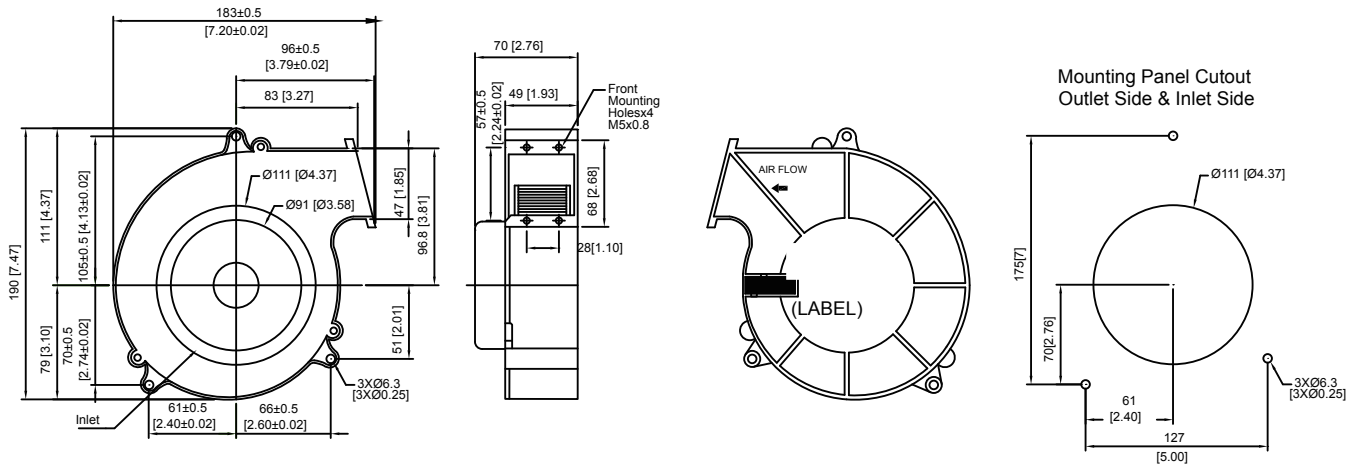

UNIT:mm[inch]

## SPECIFICATION

MODEL NO.	RATED VOLTAGE (V)	RATED CURRENT (A)	INPUT POWER (W)	SPEED (RPM)	MAX. AIR PRESSURE		MAX. AIR FLOW		NOISE dB(A) @1M
					inchH <sub>2</sub> O	mmH <sub>2</sub> O	CFM	m <sup>3</sup> /min	
DB18970V24HB	24	2.20	52.8	3000	1.97	50	90	2.55	68
DB18970V24MB	24	1.60	38.4	2700	1.57	40	80	2.26	63
DB18970V24LB	24	0.86	20.6	2200	0.79	20	64	1.81	52
DB18970V48HB	48	1.10	52.8	3000	1.97	50	90	2.55	68
DB18970V48MB	48	0.80	38.4	2700	1.57	40	80	2.26	63
DB18970V48LB	48	0.43	20.6	2200	0.79	20	64	1.81	52

## AIR PERFORMANCE

