

**MS2012HT SERIES ~ Low Profile Ceramic Chip Inductors**



**PART NUMBERING SYSTEM**

<b>MS</b>	<b>2012HT</b>	<b>—</b>	<b>10NJ</b>	<b>—</b>	<b>LF</b>
TYPE	DIMENSIONS		INDUCTANCE		LEAD FREE

**SHAPES AND DIMENSIONS**

UNIT : mm

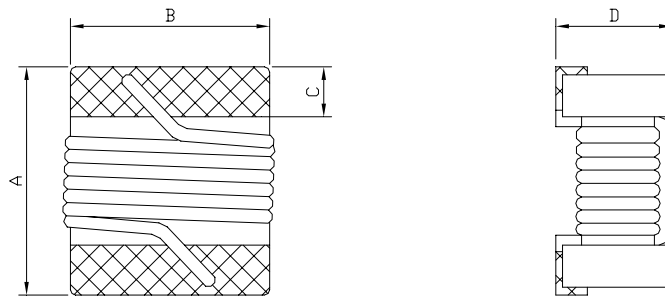

**A=2.16 Max. B=1.52 Max. C=0.43 Ref. D=0.89 Max.**

**RECOMMENDED PATTERNS**

UNIT : mm

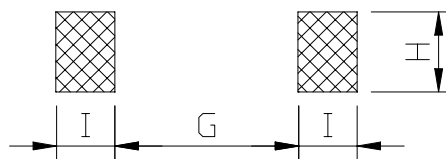

**G=0.76 H=1.78 I=1.02**

**FEATURES :**

- lowest profile chip inductors **only 0.89mm high** .( size : 2.16Lx1.52Wx0.89Ht mm Max. )
- Exceptionally **high Q compared to non-wire wound inductors**, especially at high frequencies
- Ceramic construction for highest possible **self resonance (up to 9400 MHz)**
- Lead Free with **RoHS Compliant** .

## MS2012HT SERIES ~ Low Profile Ceramic Chip Inductors



RoHS Compliant

### SPECIFICATION TABLE

PART NUMBER	INDUCTANCE (nH)	TOLERANCE	Q. MIN.	SRF (GHz) MIN.	DCR ( $\Omega$ ) (max)	IDC (mA) (max)
MS2012HT-1N8X-LF	1.8@250MHz	B,S	55@1500MHz	9400	0.030	800
MS2012HT-3N9X-LF	3.9@250MHz	B,S	55@1000MHz	6100	0.055	800
MS2012HT-4N7X-LF	4.7@250MHz	B,S	50@1000MHz	5500	0.060	800
MS2012HT-6N8X-LF	6.8@250MHz	B,S	50@1000MHz	4800	0.080	800
MS2012HT-8N2X-LF	8.2@250MHz	B,S	50@1000MHz	4800	0.080	800
MS2012HT-10NX-LF	10@250MHz	K,J,G	55@750MHz	3300	0.080	800
MS2012HT-12NX-LF	12@250MHz	K,J,G	55@750MHz	3800	0.100	800
MS2012HT-15NX-LF	15@250MHz	K,J,G	50@500MHz	2950	0.100	800
MS2012HT-18NX-LF	18@250MHz	K,J,G	50@500MHz	3100	0.130	800
MS2012HT-22NX-LF	22@250MHz	K,J,G	50@500MHz	2900	0.150	800
MS2012HT-27NX-LF	27@250MHz	K,J,G	50@500MHz	2450	0.190	700
MS2012HT-33NX-LF	33@250MHz	K,J,G	55@500MHz	2350	0.190	600
MS2012HT-39NX-LF	39@250MHz	K,J,G	55@500MHz	2200	0.270	600
MS2012HT-47NX-LF	47@200MHz	K,J,G	50@500MHz	2000	0.300	600
MS2012HT-56NX-LF	56@200MHz	K,J,G	50@500MHz	1850	0.390	500
MS2012HT-68NX-LF	68@200MHz	K,J,G	50@500MHz	1500	0.400	500
MS2012HT-82NX-LF	82@150MHz	K,J,G	50@500MHz	1500	0.440	500
MS2012HT-R10X-LF	100@150MHz	K,J,G	50@500MHz	1200	0.640	400
MS2012HT-R12X-LF	120@150MHz	K,J,G	40@250MHz	1150	0.680	300
MS2012HT-R15X-LF	150@150MHz	K,J,G	40@250MHz	1050	0.800	300
MS2012HT-R18X-LF	180@150MHz	K,J,G	40@250MHz	830	0.860	300
MS2012HT-R22X-LF	220@150MHz	K,J,G	39@150MHz	820	1.290	200
MS2012HT-R27X-LF	270@150MHz	K,J,G	33@150MHz	790	1.400	200
MS2012HT-R33X-LF	330@150MHz	K,J,G	32@150MHz	730	1.930	200
MS2012HT-R39X-LF	390@150MHz	K,J,G	30@150MHz	765	2.800	200
MS2012HT-R47X-LF	470@150MHz	K,J,G	30@150MHz	610	3.100	200
MS2012HT-R50X-LF	500@50MHz	K,J,G	20@50MHz	585	3.200	200

Operating temperature range -40°C to +125°C , Electrical specifications at 25°C.

Temperature coefficient of inductance: +25 to +125 ppm/°C.

**MS2012HT SERIES ~ Low Profile Ceramic Chip Inductors**

**TYPICAL ELECTRICAL CHARACTERISTICS**

**INDUCTANCE vs. FREQUENCY CHARACTERISTICS**

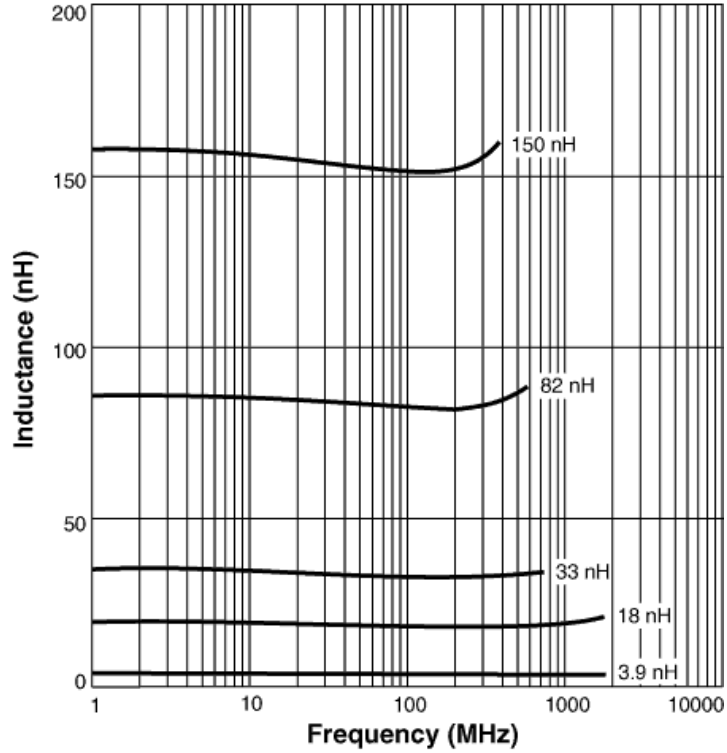

**Q vs. FREQUENCY CHARACTERISTICS**

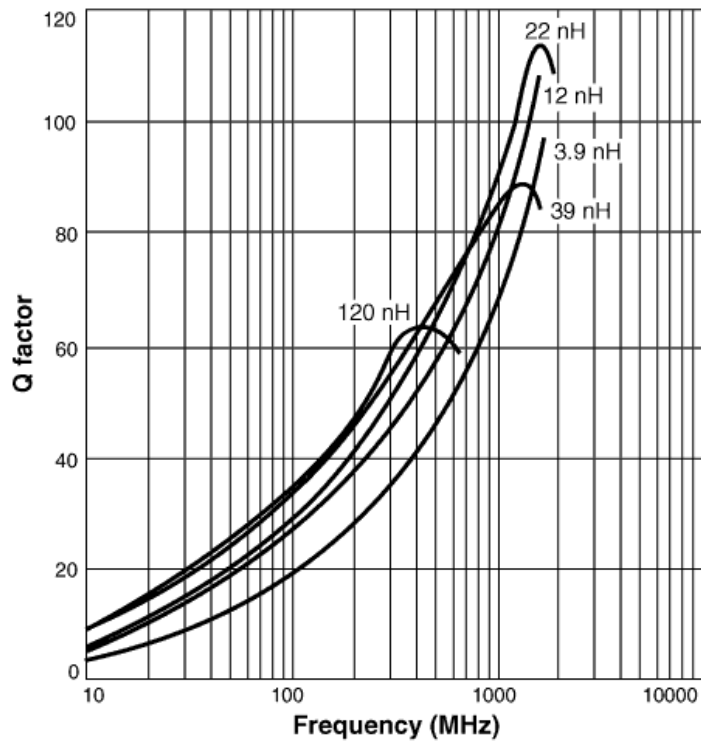

## MS2012HT SERIES ~ Low Profile Ceramic Chip Inductors



RoHS Compliant

### PACKAGING SPECIFICATION

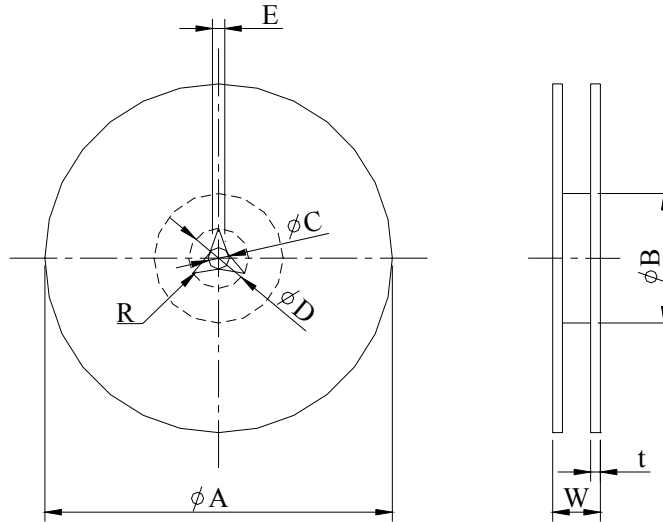

	A	B	C	D	E	W8	W12	t	R
T( $\phi$ 178mm) Reel	$\phi$ 178 $\pm$ 2	$\phi$ 60 $\pm$ 1	$\phi$ 13 $\pm$ 0.8	$\phi$ 21 $\pm$ 0.8	2	10 $\pm$ 1.5	14.5 $\pm$ 1.5	1.27 $\pm$ 0.2	1
T( $\phi$ 330mm) Reel	$\phi$ 330 $\pm$ 2	$\phi$ 100 $\pm$ 2	$\phi$ 13 $\pm$ 0.8	$\phi$ 21 $\pm$ 0.8	2	10 $\pm$ 1.5	14.5 $\pm$ 1.5	1.27 $\pm$ 0.2	1

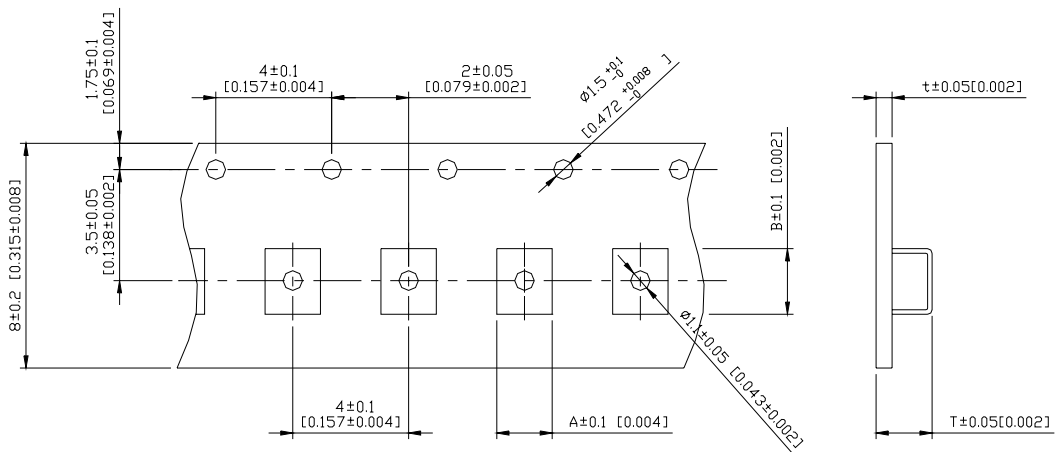

TYPE	A	B	T	t	T( $\phi$ 178mm)	T( $\phi$ 330mm)
MS2012HT	1.55	2.30	1.20	0.2	2000 pcs/reel	-