

RDS1008D SERIES ~ Through Hole Shielded Inductors



RoHS Compliant

FEATURES

- Magnetically shielded construction and low leakage flux type .
- Lead free and RoHS compliant
- Ideal for use as an inductor for high current power supplies in all types of electronic instruments .

PART NUMBERING SYSTEM

<u>RDS</u>	<u>1 0 0 8 D</u>	—	<u>1 0 0 M</u>	—	<u>LF</u>
TYPE	DIMENSIONS		INDUCTANCE		LEAD FREE

SHAPES AND DIMENSIONS

UNIT : mm

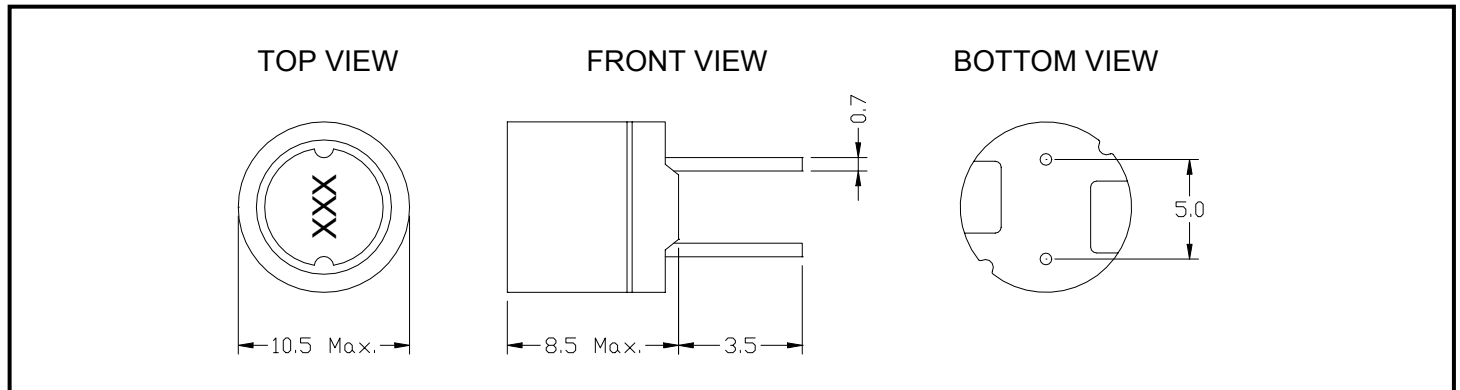

RDS1008D SERIES ~ Through Hole Shielded Inductors



RoHS Compliant

SPECIFICATION TABLE

PART NUMBER	INDUCTANCE (μ H)	DCR (Ω) (Max.)	IDC (A) (Max.)	TEST FREQ. (f)
RDS1008D-1R0N-LF	1.0 \pm 30%	6.5m	9.15	7.96MHz
RDS1008D-1R5N-LF	1.5 \pm 30%	8.5m	7.14	7.96MHz
RDS1008D-2R2N-LF	2.2 \pm 30%	9.5m	6.05	7.96MHz
RDS1008D-3R3N-LF	3.3 \pm 30%	13.5m	4.90	7.96MHz
RDS1008D-4R3N-LF	4.3 \pm 30%	14.5m	4.25	7.96MHz
RDS1008D-5R6N-LF	5.6 \pm 30%	18.5m	3.65	7.96MHz
RDS1008D-6R8N-LF	6.8 \pm 30%	20.0m	3.40	7.96MHz
RDS1008D-8R2N-LF	8.2 \pm 30%	20.5m	3.00	7.96MHz
RDS1008D-100M-LF	10 \pm 20%	0.05	2.80	1KHz
RDS1008D-120M-LF	12 \pm 20%	0.06	2.50	1KHz
RDS1008D-150M-LF	15 \pm 20%	0.07	2.30	1KHz
RDS1008D-180M-LF	18 \pm 20%	0.08	2.10	1KHz
RDS1008D-220M-LF	22 \pm 20%	0.09	2.00	1KHz
RDS1008D-270M-LF	27 \pm 20%	0.10	1.76	1KHz
RDS1008D-330M-LF	33 \pm 20%	0.11	1.60	1KHz
RDS1008D-390M-LF	39 \pm 20%	0.12	1.38	1KHz
RDS1008D-470M-LF	47 \pm 20%	0.14	1.28	1KHz
RDS1008D-560 L-LF	56 \pm 15%	0.15	1.20	1KHz
RDS1008D-680 L-LF	68 \pm 15%	0.16	1.00	1KHz
RDS1008D-820 L-LF	82 \pm 15%	0.18	0.96	1KHz
RDS1008D-101 L-LF	100 \pm 15%	0.20	0.92	1KHz
RDS1008D-121 L-LF	120 \pm 15%	0.24	0.80	1KHz
RDS1008D-151 L-LF	150 \pm 15%	0.35	0.73	1KHz
RDS1008D-181 L-LF	180 \pm 15%	0.40	0.64	1KHz
RDS1008D-221 L-LF	220 \pm 15%	0.54	0.61	1KHz
RDS1008D-271 L-LF	270 \pm 15%	0.76	0.56	1KHz
RDS1008D-331 L-LF	330 \pm 15%	0.86	0.50	1KHz
RDS1008D-391 L-LF	390 \pm 15%	0.93	0.44	1KHz
RDS1008D-471 L-LF	470 \pm 15%	1.23	0.41	1KHz
RDS1008D-561 L-LF	560 \pm 15%	1.34	0.38	1KHz
RDS1008D-681 L-LF	680 \pm 15%	1.53	0.34	1KHz
RDS1008D-821 L-LF	820 \pm 15%	2.10	0.32	1KHz
RDS1008D-102 L-LF	1000 \pm 15%	2.30	0.28	1KHz

- Inductors tolerance L= \pm 15% ; M= \pm 20% ;N= \pm 30%.
- DC current at which the inductance drops 10% (typ) from its value without current.
- Operating temperature range -25°C to +105°C .
- Electrical specifications at 20°C .