

SMM 1710B SERIES ~

SMT Common Mode Chokes



RoHS Compliant

PART NUMBERING SYSTEM

SMM	1710B	—	591	—	LF
TYPE	DIMENSIONS		IMPEDANCE		LEAD FREE

SHAPES AND DIMENSIONS

UNIT : mm

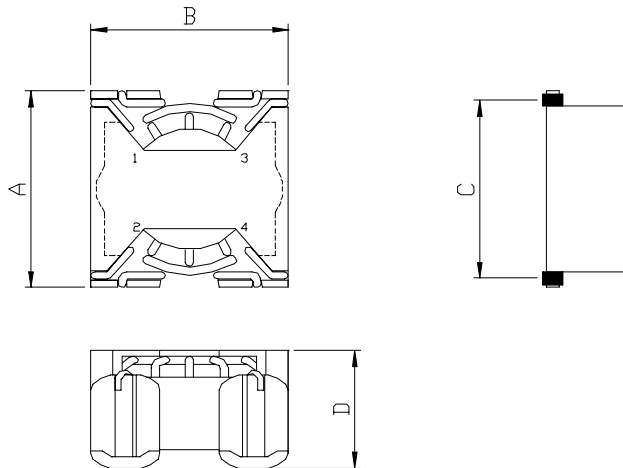

A= 19.56 Max. B= 17.02 Max. C= 16.51 Max. D= 9.91 Max.

PCB LAYOUT

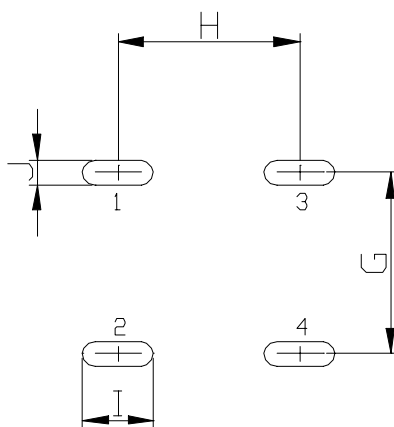

Schematic

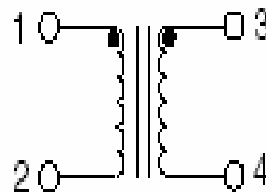

G= 16.76 H= 11.3 I= 4.45 J= 1.52 Ref.

SMM 1710B SERIES ~

SMT Common Mode Chokes



RoHS Compliant

FEATURES

- **Exceptionally low DC resistance** thanks to the use of heavier gauge wire
- Solutions based on impedance , size and current
- Designed for DC-DC Converters
- Wide Variety of inductor sizes and current ratings available
- Dielectric strength : **1000Vrms** .
- **RoHS-compliant**. 260°C compatible. Tin-silver over copper terminations

SPECIFICATION TABLE

PART NUMBER	INDUCTANCE (μ H)	I _{rated} (A)	DCR (m Ω) (Max.)	Test Freq.
SMM1710B-221-LF	220 \pm 35%	3.30	60.0	10KHz / 1V
SMM1710B-591-LF	590 \pm 35%	4.70	21.0	10KHz / 1V
SMM1710B-771-LF	220 \pm 35%	5.60	40.0	10KHz / 1V
SMM1710B-132-LF	1320 \pm 35%	3.30	60.0	10KHz / 1V
SMM1710B-142-LF	1470 \pm 35%	2.80	80.0	10KHz / 1V
SMM1710B-601-LF	600 Min.	3.60	50.0	10KHz / 1V
SMM1710B-182-LF	1800 Min.	2.50	80.0	10KHz / 1V

- Inductance is measured with a LCR meter 4284A or equivalent.
- Operating temperature range -40°C to +85°C.
- Electrical specifications at 25°C .
- Packing : 13" reel, machine-ready ,embossed plastic tape (200 parts per full reel).