

Common Mode Choke ~ CMT2510B SERIES



RoHS Compliant

PART NUMBERING SYSTEM

CMT	2510B	—	102N	—	LF
TYPE	DIMENSIONS		IMPEDANCE		LEAD FREE

SHAPES AND DIMENSIONS

UNIT : mm

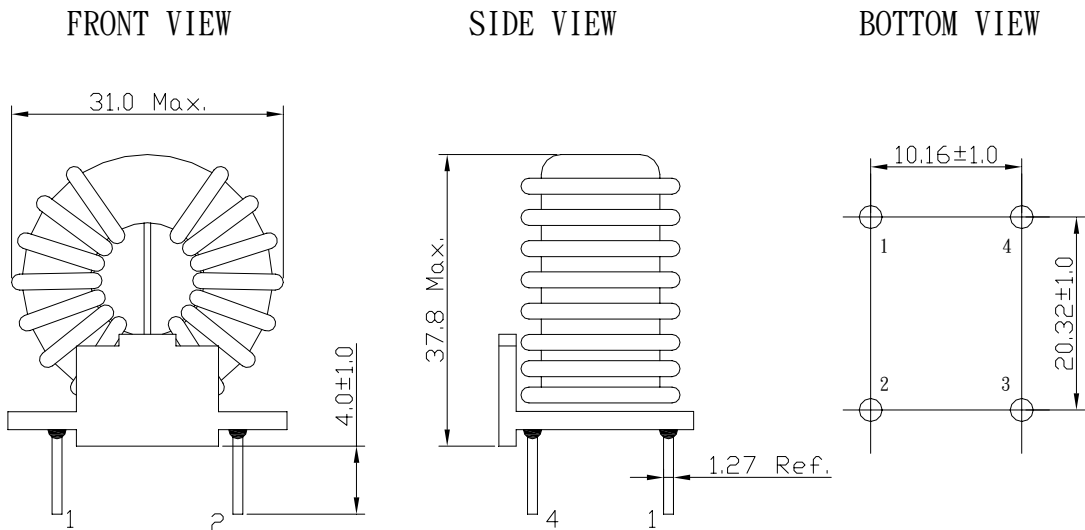

SCHEMATIC DRAWING

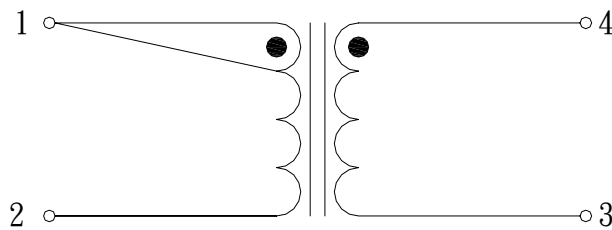

Common Mode Choke ~ CMT2510B SERIES



RoHS Compliant

SPECIFICATION TABLE

PART NUMBER	INDUCTANCE (mH)	DCR (mΩ) (max)	IDC (A) (max)	NOMINAL VOLTAGE V _{AC}	TEST FREQ. (f)
CMT2510B-102N-LF	1.0±30%	10	10.0	250	10KHz
CMT2510B-142N-LF	1.4±30%	19	8.0	250	10KHz
CMT2510B-192N-LF	1.9±30%	19	7.0	250	10KHz
CMT2510B-222N-LF	2.2±30%	20	6.0	250	10KHz
CMT2510B-332N-LF	3.3±30%	35	4.0	250	10KHz
CMT2510B-402N-LF	4.0±30%	45	4.0	250	10KHz
CMT2510B-502N-LF	5.0±30%	50	4.0	250	10KHz
CMT2510B-702N-LF	7.0±30%	80	3.5	250	10KHz
CMT2510B-103N-LF	10.0±30%	105	3.0	250	10KHz
CMT2510B-203N-LF	20.0±30%	220	2.0	250	10KHz

- Inductance is measured with a LCR meter 4284A or equivalent.
- Test voltage : 1500V, 50Hz , 5mA , 2sec.
- Operating temperature range -40°C to +125°C
- Electrical specifications at 25°C