

ET35LFH SERIES - Common Mode Choke Coil



RoHS Compliant

AC Line Filters

PART NUMBERING SYSTEM

<u>ET</u>	<u>35LFH</u>	—	<u>183</u>	—	<u>LF</u>
TYPE	DIMENSIONS		IMPEDANCE		LEAD FREE

SHAPES AND DIMENSIONS

UNIT : mm

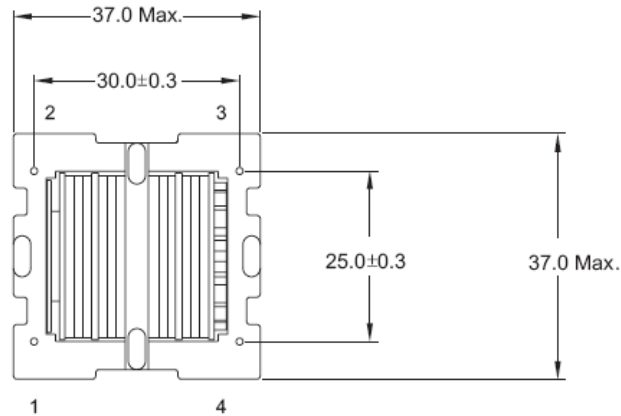
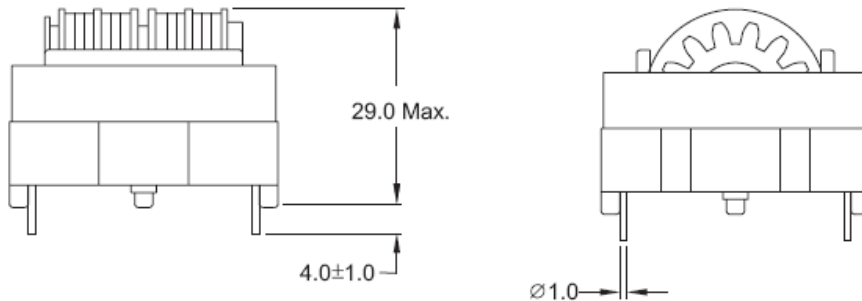

Schematic :

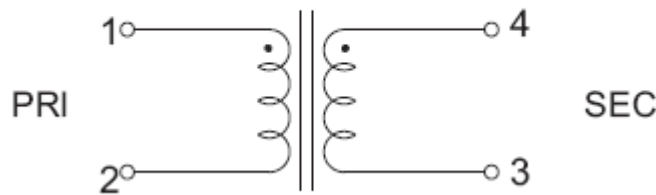

ET35LFH SERIES - Common Mode Choke Coil

AC Line Filters



RoHS Compliant

ELECTRICAL CHARACTERISTICS :

PART NUMBER	Common Mode Inductance (mH)	RATED CURRENT (Aac)	DCR mohm (V)	INSULATION RESISTANCE (M ohm)
ET35LFH-272-LF	2.70min.	5.0	36	100min.
ET35LFH-332-LF	3.30min.	4.3	47	100min.
ET35LFH-442-LF	4.40min.	4.0	55	100min.
ET35LFH-522-LF	5.20min.	3.5	77	100min.
ET35LFH-832-LF	8.30min.	3.0	96	100min.
ET35LFH-133-LF	13.0min.	2.5	147	100min.
ET35LFH-183-LF	18.0min.	2.0	220	100min.
ET35LFH-293-LF	29.0min.	1.6	320	100min.
ET35LFH-343-LF	34.0min.	1.4	416	100min.
ET35LFH-483-LF	48.0min.	1.1	590	100min.

- 1) Test Frequency : 40KHZ / 1V
- 2) Operating Temperature Range : -40°C to + 85 °C range is application specific.
- 3) Winding Temperature Rise (at Rated Current) : 60K max.
- 4) Packaging : Supplied in bulk packaging.