

SS1060 SERIES ~ Spring Air Core Inductors



RoHS Compliant

SHAPE AND DIMENSION

FEATURES

- SMD type air core inductor .
- Tape / Reel packaging available for auto-insertion .
- High Q coils .

SS1060 Series

unit : mm

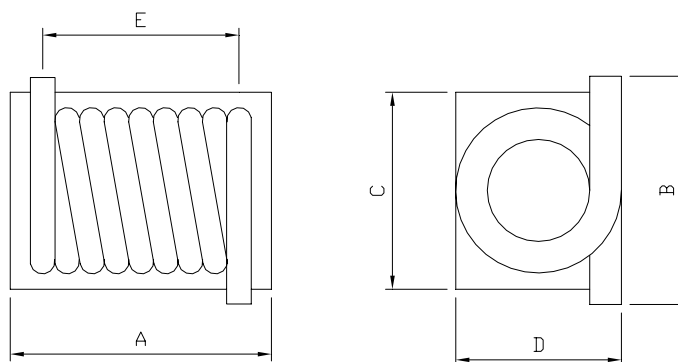

A=10.55 Max. B=6.6 Max C=5.74±0.08 D=5.97 Max. E=7.98±0.51

PART NUMBER	INDUCTANCE (nH)	Tolerance	Q. (Min.)	DCR (mΩ) (Max)	SRF (GHz) (Min.)	I _{rms} (A) (Max)
SS1060-90□-LF	90	J , K	114	15	3.2	3.5
SS1060-R11□-LF	111	J , K	104	15	2.7	3.5
SS1060-R13□-LF	130	J , K	104	20	2.5	3.0
SS1060-R17□-LF	169	J , K	114	25	2.1	3.0
SS1060-R20□-LF	206	J , K	114	30	2.1	3.0
SS1060-R22□-LF	222	J , K	110	35	1.5	3.0
SS1060-R24□-LF	246	J , K	114	35	1.5	3.0
SS1060-R30□-LF	307	J , K	114	35	1.3	3.0
SS1060-R38□-LF	380	J , K	114	50	1.2	2.5
SS1060-R42□-LF	422	J , K	114	60	1.1	2.5
SS1060-R49□-LF	491	J , K	114	65	1.2	2.0
SS1060-R54□-LF	538	J , K	104	90	1.1	2.0

* Inductance tested at 150MHz. Inductance tolerance : J=+/-5% K=+/-10%

* Operating temperature range : -40°C to +125°C.