

SS3730 SERIES ~ Spring Air Core Inductors



RoHS Compliant

SHAPE AND DIMENSION

FEATURES

- SMD type air core inductor .
- Tape / Reel packaging available for auto-insertion .
- High Q coils .

SS3730 Series

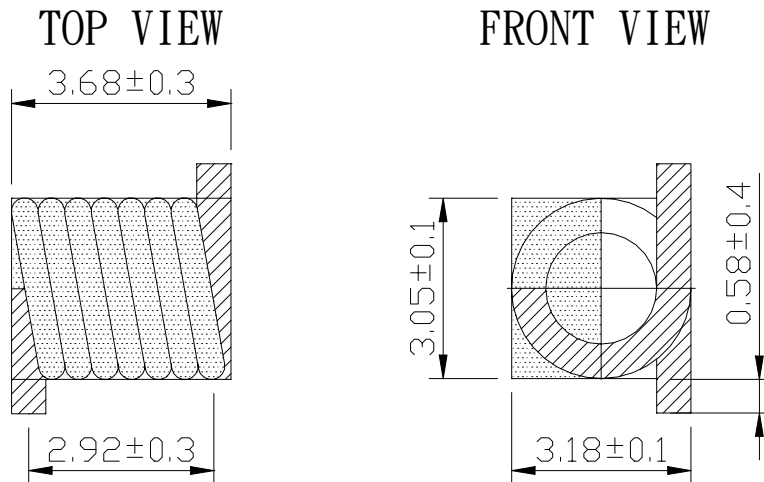

SS3730 SERIES

PART NUMBER	INDUCTANCE	Tolerance	Q. (Min.)	DCR (mΩ)	SRF (GHz)	Irms (A)
	(nH)			(Max)	(Min.)	(Max)
SS3730-2N5X-LF	2.5	K	145	1.1	12.5	4
SS3730-5N0X-LF	5.0	J, K	140	1.8	6.5	4
SS3730-8N0X-LF	8.0	J, K	140	2.6	5.0	4
SS3730-12NX-LF	12.5	J, K	137	3.4	3.3	4
SS3730-18N X-LF	18.5	J, K	132	3.9	2.5	4

* Inductance tested at 150MHz.

* Inductance tolerance : K=+/-10% ; J=+/-5%.

* Operating temperature range : -40°C to +125°C.