

SMD Current Sense Transformer ~ EE5XFS-LF SERIES

PART NUMBERING SYSTEM



RoHS Compliant

SHAPES AND DIMENSIONS

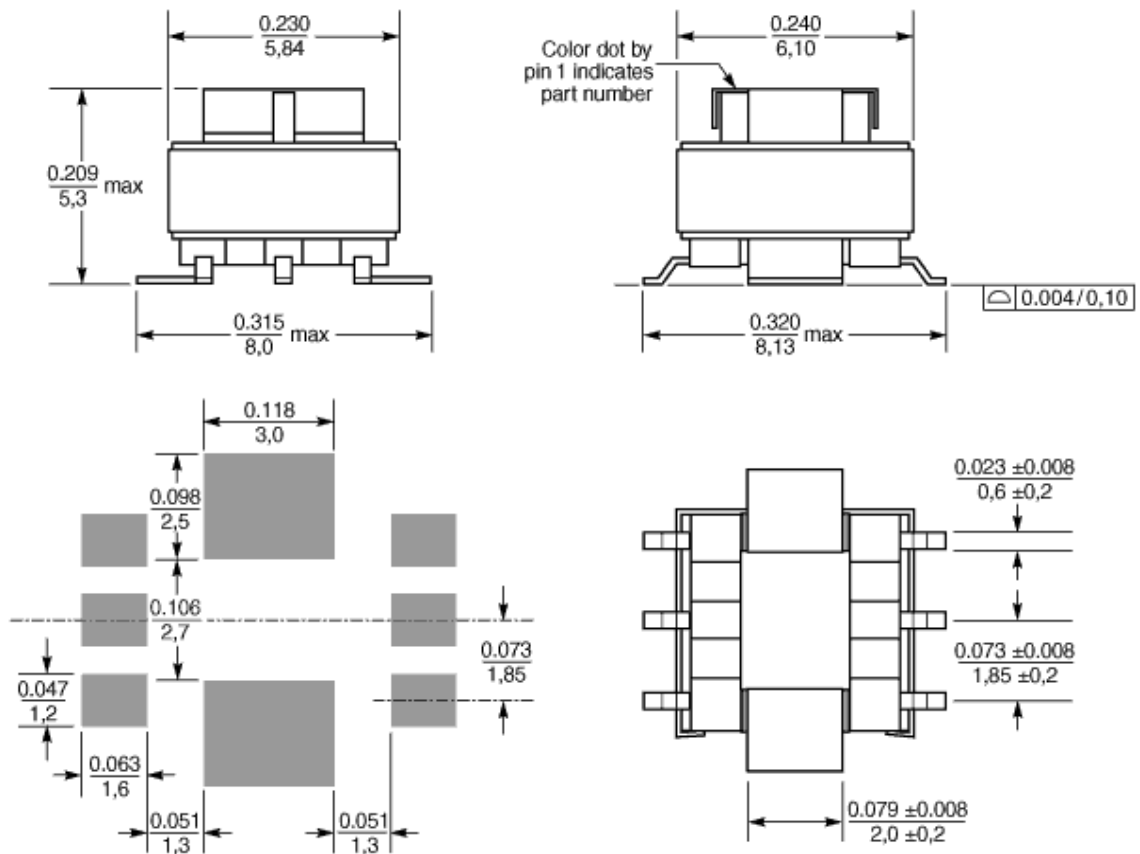

Recommended Land Pattern

Secondary windings to be connected in parallel on the PC board

SMD Current Sense Transformer ~ EE5XFS-LF SERIES

FEATURES

- 1 **Height: 5.1mm NOM (5.3mm Max)** , Footprint: 8.4mm*7.2mm Max
- 2 **Senses current to greater than 10 Amps**
- 3 **Frequency Range: 50kHz to 1MHz**
- 4 **500 V isolation winding to winding**
- 5 **8 different turns ratios to meet variety of requirements**
- 6 **RoHS-compliant.** 260°C compatible.



RoHS Compliant

SCHEMATIC

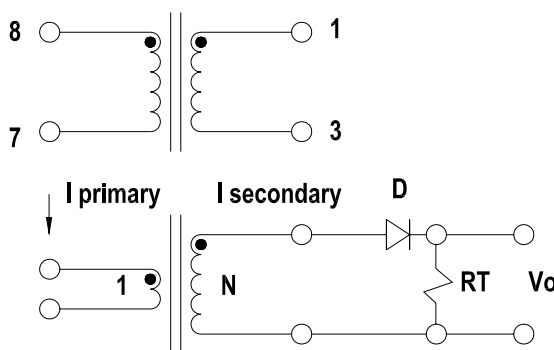

APPLICATION CIRCUIT

ELECTRICAL CHARACTERISTICS :

PART NUMBER	OCL(1-3)mH (uH)@ 0A	DCR(ohm) MAX		Senses current lin(A)	Turns ratio Pri : Sec	Hi-pot Vrms
		Pri	Sec			
EE5XFS-800-LF	81 Min.	0.006	0.55	10	01:20	3.3V ; 4.5A
EE5XFS-181-LF	180 Min.	0.006	0.87	10	01:30	5.0V ; 3.0A
EE5XFS-321-LF	320 Min.	0.006	1.14	10	01:40	12V ; 1.25A
EE5XFS-501-LF	500 Min.	0.006	1.50	10	01:50	3.3V ; 4.5A
EE5XFS-731-LF	730 Min.	0.006	2.25	10	01: 60	5.0V ; 3.0A
EE5XFS-981-LF	980 Min.	0.006	4.75	10	01: 70	12V ; 1.25A
EE5XFS-202-LF	2000 Min.	0.006	5.50	10	01: 100	3.3V ; 4.5A
EE5XFS-302-LF	3000 Min.	0.006	6.50	10	01: 125	3.3V ; 4.5A

- 1) Inductance measured across secondary at 100 kHz, 0.1 Vrms.
- 2) Ambient temperature range: -40°C to +85°C
- 3) Storage temperature range: Component: -40°C to +85°C
- 4) Resistance to soldering heat: Three reflows at >217°C for 90 seconds (+260°C ±5°C for 20 – 40 seconds), allowing parts to cool to room temperature between.