



## SMD Current Sense Transformer ~ EF12.6XFS-LF SERIES

### FEATURES

- 1 **Height: 10.2mm Max** , Footprint: 19.9mm\*14.5mm Max
- 2 **Current Rating: up to 35A**
- 3 **Frequency Range: 50kHz to 500kHz**
- 4 **500 V isolation winding to winding**
- 5 **Low primary DCR**
- 6 **RoHS-compliant.** 260°C compatible.

### SCHEMATIC

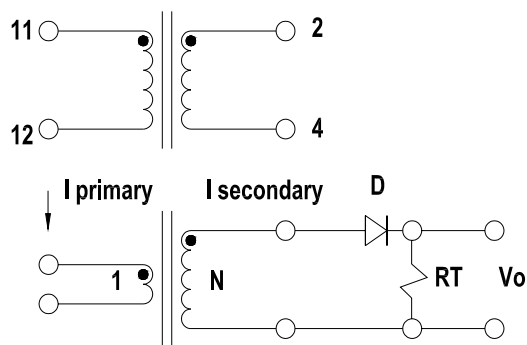

APPLICATION CIRCUIT

### ELECTRICAL CHARACTERISTICS :

PART NUMBER	OCL(2-4) ( mH )@ 0A	DCR(2-4) (ohm )TYP.	DCR(11-12) (mohm )TYP.	Hi-pot Vrms
EE12.6XFS-152-LF	1.5 Min.	0.65	0.28	500
EE12.6XFS-602-LF	6.0 Min.	2.00	0.28	500
EE12.6XFS-103-LF	10.0 Min.	4.50	0.28	500
EE12.6XFS-253-LF	25.0 Min.	15.0	0.28	500

- 1) Inductance measured across secondary at 100 kHz, 0.1 Vrms.
- 2) Ambient temperature range: -40°C to +85°C
- 3) Storage temperature range: Component: -40°C to +85°C
- 4) Resistance to soldering heat: Three reflows at >217°C for 90 seconds (+260°C ±5°C for 20 – 40 seconds), allowing parts to cool to room temperature between.