

Planar Transformers ~ PE40RX-LF SERIES

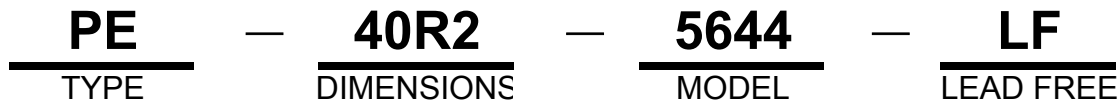

PART NUMBERING SYSTEM



FEATURES

1. Power Rating : to **150W** forward converter
2. Height : Both type for **7.40mm Max. and 9.8mm Max.**
3. **Footprint : 23.3x21.2 mm Max.**
4. Frequency range from 100KHz to 700KHz typical .
5. **Isolation** (Primary to Secondary & core) : **1750Vdc**
6. RoHS-compliant. 260°C compatible.

SHAPES AND DIMENSIONS

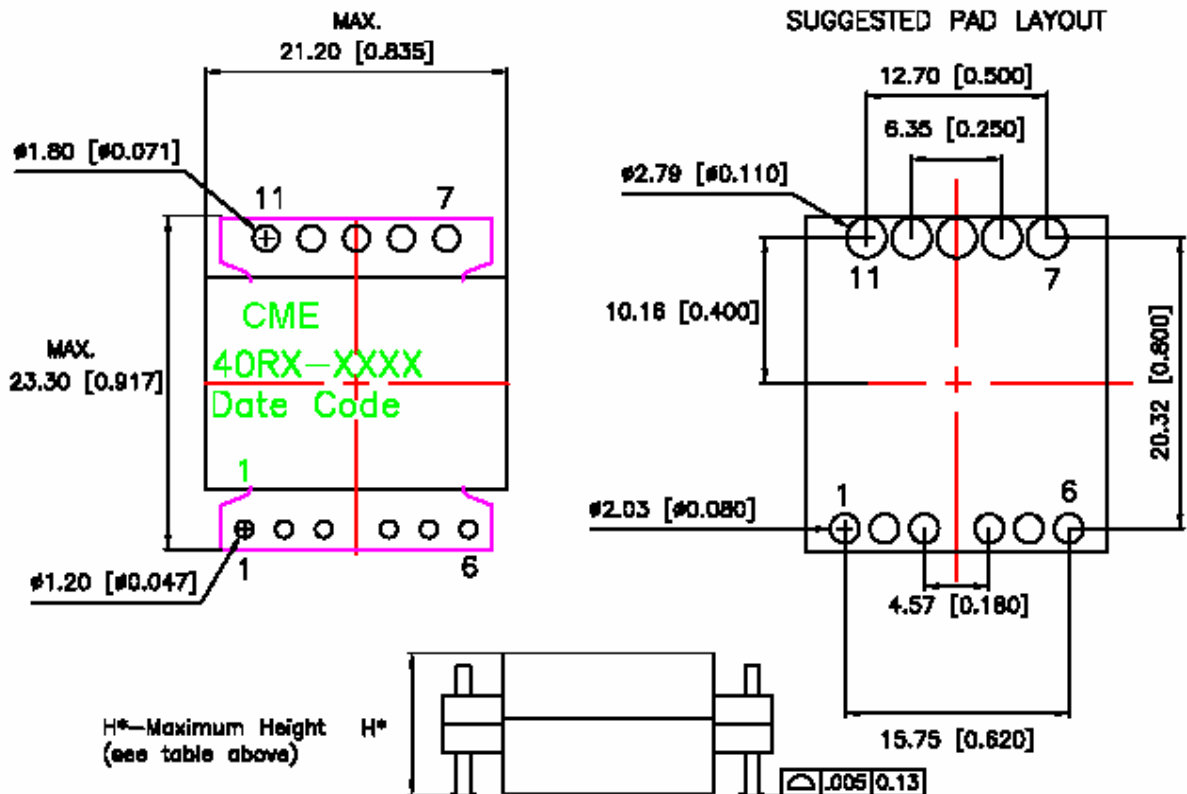

Planar Transformers ~ PE40RX-LF SERIES



RoHS Compliant

Inductance vs Current Characteristics

Schematics

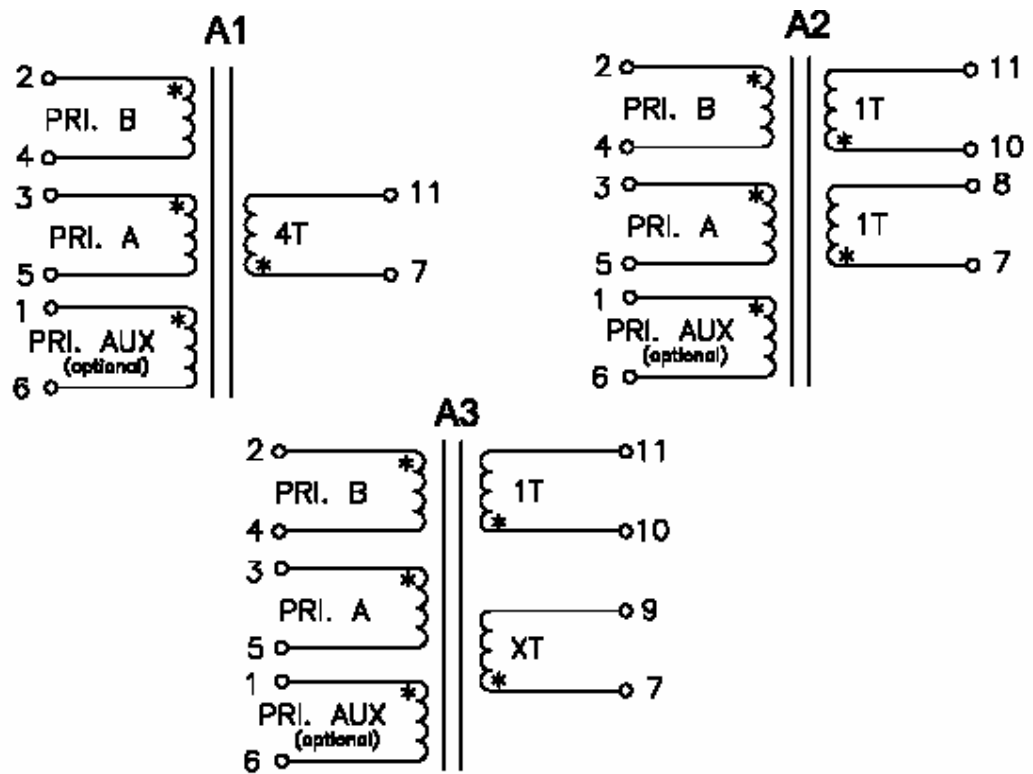

Planar Transformers ~ PE40RX-LF SERIES

ELECTRICAL CHARACTERISTICS :

PART NUMBER	Primary Inductance (uH Min.)	Leakage Inductance (uH typ.)	DCR (mΩ) typ.			Turns			Ht (mm) Max.	Schematic
			Pri. A	Pri. B	Sec.	Pri. A	Pri. B	Sec.		
Single Interleave Designs										
PE40R1-3444-LF	117	0.100	9	15	7.0	3T	4T	4T	7.4	A1
PE40R1-4444-LF	153	0.100	15	15	7.0	4T	4T	4T	7.4	A1
PE40R1-4544-LF	194	0.100	15	26	7.0	4T	5T	4T	7.4	A1
PE40R1-5544-LF	240	0.100	26	26	7.0	5T	5T	4T	7.4	A1
PE40R1-5644-LF	290	0.150	26	36	7.0	5T	6T	4T	7.4	A1
PE40R1-6644-LF	345	0.150	36	36	7.0	6T	6T	4T	7.4	A1
PE40R1-3411-LF	117	0.200	9	15	1&1	3T	4T	1T&1T	7.4	A2
PE40R1-4411-LF	153	0.200	15	15	1&1	4T	4T	1T&1T	7.4	A2
PE40R1-4511-LF	194	0.300	15	26	1&1	4T	5T	1T&1T	7.4	A2
PE40R1-5511-LF	240	0.300	26	26	1&1	5T	5T	1T&1T	7.4	A2
PE40R1-5611-LF	290	0.500	26	36	1&1	5T	6T	1T&1T	7.4	A2
PE40R1-6611-LF	345	0.500	36	36	1&1	6T	6T	1T&1T	7.4	A2
PE40R1-3421-LF	117	0.200	9	15	4&1	3T	4T	2T&1T	7.4	A3
PE40R1-4421-LF	153	0.200	15	15	4&1	4T	4T	2T&1T	7.4	A3
PE40R1-4521-LF	194	0.300	15	26	4&1	4T	5T	2T&1T	7.4	A3
PE40R1-5521-LF	240	0.300	26	26	4&1	5T	5T	2T&1T	7.4	A3
PE40R1-5621-LF	290	0.500	26	36	4&1	5T	6T	2T&1T	7.4	A3
PE40R1-6621-LF	345	0.550	36	36	4&1	6T	6T	2T&1T	7.4	A3
PE40R1-4431-LF	153	0.200	15	15	9&1	4T	4T	3T&1T	7.4	A3
PE40R1-4531-LF	194	0.300	15	26	9&1	4T	5T	3T&1T	7.4	A3

Note : Inductance is measured with both primary windings connected in series (2 to 5 , with 3 & 4 shorted)

Leakage inductance is measured on winding (2 to 4) with all other windings shorted .

Planar Transformers ~ PE40RX-LF SERIES

ELECTRICAL CHARACTERISTICS :

PART NUMBER	Primary Inductance (uH Min.)	Leakage Inductance (uH typ.)	DCR (mΩ) typ.			Turns			Ht (mm) Max.	Schematic
			Pri. A	Pri. B	Sec.	Pri. A	Pri. B	Sec.		
Double Interleave Designs										
PE40R2-3444-LF	117	0.100	5	8	4.0	3T	4T	4T	9.8	A1
PE40R2-4444-LF	153	0.100	8	8	4.0	4T	4T	4T	9.8	A1
PE40R2-4544-LF	194	0.100	8	14	4.0	4T	5T	4T	9.8	A1
PE40R2-5544-LF	240	0.100	14	14	4.0	5T	5T	4T	9.8	A1
PE40R2-5644-LF	290	0.150	14	19	4.0	5T	6T	4T	9.8	A1
PE40R2-6644-LF	345	0.150	19	19	4.0	6T	6T	4T	9.8	A1
PE40R2-3411-LF	117	0.100	5	8	0.6&0.6	3T	4T	1T&1T	9.8	A2
PE40R2-4411-LF	153	0.100	8	8	0.6&0.6	4T	4T	1T&1T	9.8	A2
PE40R2-4511-LF	194	0.100	8	14	0.6&0.6	4T	5T	1T&1T	9.8	A2
PE40R2-5511-LF	240	0.100	14	14	0.6&0.6	5T	5T	1T&1T	9.8	A2
PE40R2-5611-LF	290	0.150	14	19	0.6&0.6	5T	6T	1T&1T	9.8	A2
PE40R2-6611-LF	345	0.150	19	19	0.6&0.6	6T	6T	1T&1T	9.8	A2
PE40R2-3421-LF	117	0.100	5	8	1.7&0.6	3T	4T	2T&1T	9.8	A3
PE40R2-4421-LF	153	0.100	8	8	1.7&0.6	4T	4T	2T&1T	9.8	A3
PE40R2-4521-LF	194	0.100	8	14	1.7&0.6	4T	5T	2T&1T	9.8	A3
PE40R2-5521-LF	240	0.100	14	14	1.7&0.6	5T	5T	2T&1T	9.8	A3
PE40R2-5621-LF	290	0.150	14	19	1.7&0.6	5T	6T	2T&1T	9.8	A3
PE40R2-6621-LF	345	0.150	19	19	1.7&0.6	6T	6T	2T&1T	9.8	A3
PE40R2-4431-LF	153	0.100	8	8	5&0.6	4T	4T	3T&1T	9.8	A3
PE40R2-4531-LF	194	0.100	8	14	5&0.6	4T	5T	3T&1T	9.8	A3

Note : Inductance is measured with both primary windings connected in series (2 to 5 , with 3 & 4 shorted)

Leakage inductance is measured on winding (2 to 4) with all other windings shorted .